

FPS System

Fence Protection System

FPS-3 Installation & Operation Guide

G2DA0302-001, Rev A
First edition
September 15, 2009



Senstar Corporation

119 John Cavanaugh Drive
Carp, Ontario
Canada K0A 1L0
Tel: +1 (613)-839-5572
Fax: +1 (613)-839-5830
Website: www.senstar.com
Email address: info@senstar.com

G2DA0302-001, Rev A

First edition

September 15, 2009

Senstar is a registered trademark, and the Senstar logo is a trademark of Senstar Corporation. Product names and Company names used in this document are included for identification purposes only, and are the property of, and may be trademarks of, their respective owners. Copyright © 2009 Senstar Corporation. All rights reserved. Printed in Canada.

The information provided in this guide has been prepared by Senstar Corporation to the best of its ability. Senstar Corporation is not responsible for any damage or accidents that may occur due to errors or omissions in this guide. Senstar Corporation is not liable for any damages, or incidental consequences, arising from the use of, or the inability to use, the software and equipment described in this guide. Senstar Corporation is not responsible for any damage or accidents that may occur due to information about items of equipment or components manufactured by other companies. Features and specifications are subject to change without notice. Any changes or modifications to the software or equipment that are not expressly approved by Senstar Corporation void the manufacturer's warranty, and could void the user's authority to operate the equipment.

Senstar's Quality Management System is ISO 9001:2000 registered.



Limited Warranty

- a) The Company warrants that the electronic components of the products manufactured by the Company are free from all manufacturing defects. The Company's warranty does not extend to the performance of the products, which may vary depending on environmental conditions, use and installation practices. The Company's liability under this warranty shall be limited to, at its option, either repairing or replacing the defective components of the products or granting a credit for the products or parts thereof. The Company's liability shall apply only to products which are returned to the factory or authorized repair point, transportation charges prepaid by the Buyer within one (1) year from the shipment date of the product from the Company and which are, after examination, disclosed to Company's satisfaction to be defective due to defects in workmanship and/or materials. This warranty shall not apply to any products which have been installed, repaired or altered by other than personnel certified by the Company, or to products which have been subject to physical or electrical abuse, misuse, or improper storage or to products which have not been used or maintained in compliance with any applicable recommendations of the Company. This warranty does not apply to any parts or components of the products, which are normally consumed in operation, including but not limited to batteries, fuses and light bulbs.
- b) The Company specifically disclaims any and all warranties, expressed or implied, including but not limited to any warranties or merchantability or fitness for a particular purpose. Under no circumstances be it due to a breach of warranty or any other cause arising out of the performance or non-performance of the Product shall the Company be liable to the Buyer for incidental or consequential damages, including but not limited to: lost profits, loss of property due to the freight, plant downtimes, or suits by third parties.

CONTENTS

	PAGE
1 QUICK START	1
2 GENERAL	10
3 THEORY OF OPERATION	11
4 FENCE CONDITIONS	14
5 INSTALLATION	18
6 SYSTEM START UP AND TESTING	45
7 MAINTENANCE/TROUBLESHOOTING	52
 ADDENDUM I – FIELD PERFORMANCE ANALYZER	 A-1

LIST OF FIGURES	PAGE
Figure 1	Typical MX-5300/FPS System Connections 2
Figure 2	Fence Mounted FPS Dual Zone Pre-Amp 3
Figure 3	Cable Tie Installation 4
Figure 4	Dual Zone Pre-Amp Cable Connections 4
Figure 5	MPS-4100 Microwave Installation 5
Figure 6	MPS Connections to FPS-3 via Dual Zone Relay Input Card 6
Figure 7	MX-5300 Power Supply Connections 7
Figure 8	Central Controller Connections 8
Figure 9	MX-5300 Loop Connections 9
Figure 10	FPS-3 System 10
Figure 11	Alarm Zone Connections 12
Figure 12	Block Diagram 13
Figure 13	Loose Fabric at Fence Posts 14
Figure 14	Loose Fabric at Diagonal Stiffeners 14
Figure 15	Loose Fabric at Wire Stiffeners 15
Figure 16	Dangling Barbed Wire 15
Figure 17	Improperly Secured Brackets 15
Figure 18	Missing Vertical Locking Posts 15
Figure 19	Excessive Play 16
Figure 20	Loose Chain and Lock 16
Figure 21	Roller and Rail Play 16
Figure 22	Signs Not Securely Attached 16
Figure 23	Fence-mounted Pre-amp 19
Figure 24	Pre-Amp Remote Mounting 21
Figure 25	Pre-Amp Pedestal Mounting 22
Figure 26	Unreeling Cable 23
Figure 27	Cable Tie Installation 24
Figure 28	Transducer Cable Around Fence Post 25
Figure 29	Transducer Cable Service Loop 25
Figure 30	Increasing Transducer Cable Sensitivity 26
Figure 31	Zone Overlap 27
Figure 32	Helisensor/Sensor Cable Termination- Single Run 30
Figure 33	Helisensor/Sensor Double Run Installation/ Termination 31
Figure 34	Transducer Cable Routing in Condulet 32
Figure 35	Transducer Cable Connection 32

LIST OF FIGURES	PAGE
Figure 36	End-of-Line Termination 33
Figure 37	Splice Termination 33
Figure 38	End-of-Line Termination With 2 Megaohm Resistor 33
Figure 39	EOL Condulet Attached To Fence 34
Figure 40	Condulet Splice Attached To Fence 34
Figure 41	Condulet "G" Attached To Fence 34
Figure 42	Transducer Service Kit 36
Figure 43	Transducer Cable Preparation 36
Figure 44	Hinged Gate Installation 37
Figure 45	Telegate Installation 38
Figure 46	Telegate Support Post Location 39
Figure 47	MPS Microwave System 41
Figure 48	Pre-Amp Cable Connections 42
Figure 49	Central Controller Cable Connections 43
Figure 50	Dual Zone Relay Input Card Wiring 44
Figure 51	Interface Board Connections and Controls 46
Figure 52	Dual Zone Card 46
Figure A-1	Field Performance Analyzer A-3

LIST OF TABLES	
Table 1	Sensor Cable Capacitance 13
Table 2	Field Measured Gain and Count Settings 51
Table 3	FPS-3 Troubleshooting Table 56
Table 4	Interface Board Fault Isolation Matrix 58

FENCE PROTECTION SYSTEMS

1 QUICK START

Qualified technicians may follow these simplified procedures to install and test the FPS-3 Fence Protection System. Prerequisites for using the quick start procedures are:

- Attendance at one or more Magal-Senstar FPS-3 training class.
- Prior MX-5000 or MX-5300 field installation experience.

Before proceeding, VERIFY that you have a complete site layout showing zone extents, processor locations, and conduit interconnections. If you are not familiar with any of the procedures described in this section, refer to the appropriate manual for more detailed information.

IMPORTANT PROCEDURES

Throughout the installation it is very important that certain procedures are observed:

Install ground rods and proper grounding at the MX-5300, all FPS-3 fence-mounted pre-amps, and all microwave locations.

Use only the approved multiconductor shielded cable for connecting the MX-5300 FPS-3 Central Controller to the FPS and MPS units.

Terminate wiring and shields *exactly* as shown. Improper terminations will cause system noise and degrade performance.

The FPS-3 Central Controller must be installed within 100 feet of the MX-5300.

Installation

Figure 1 shows the typical wiring interconnection of components.

- The interconnect wiring should be run in conduit, either underground or along the base of the fence.
- The interconnect cable must be an approved two-pair, 24-gauge, individually shielded twisted pair low capacitance cable, with high density polyethylene jacket, such as the Magal-Senstar FPS Interconnect Cable or factory-approved equal.

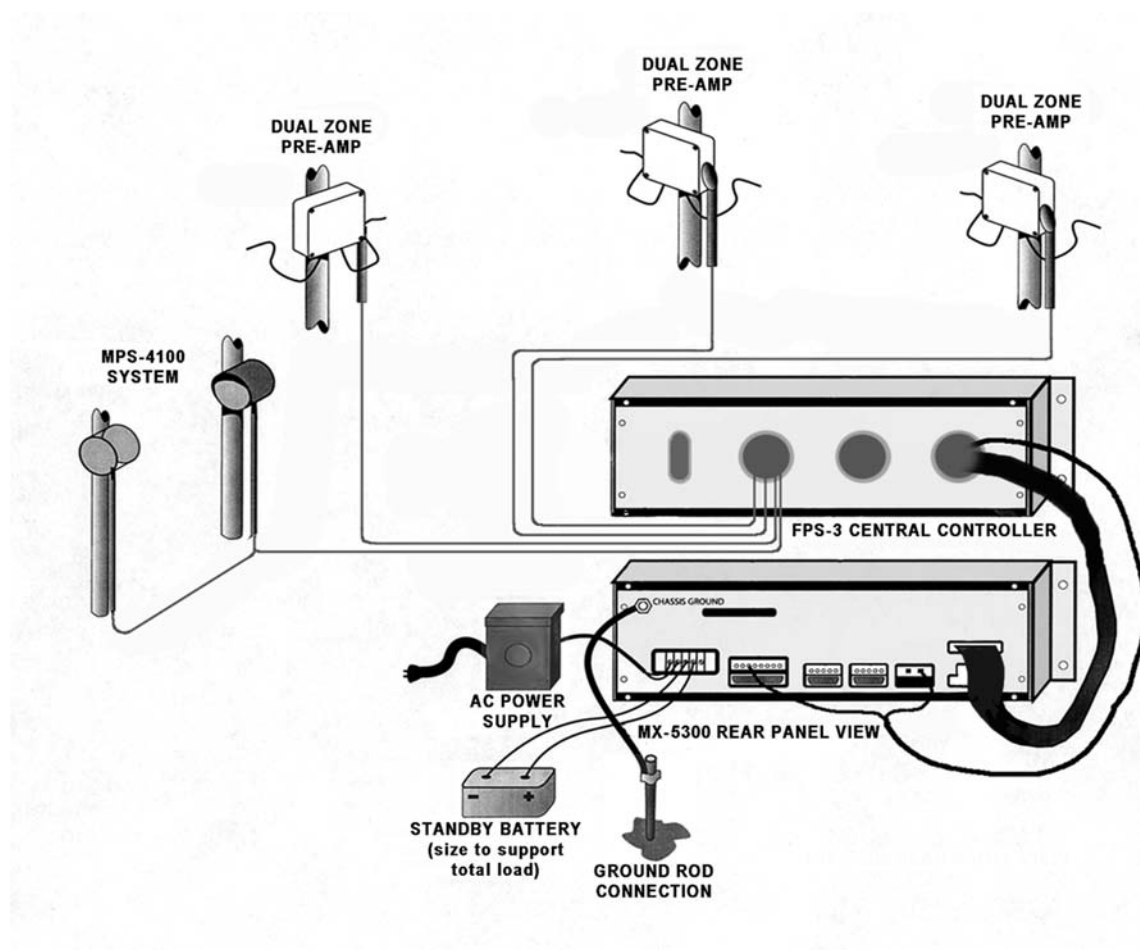

Figure 1. Typical MX-5300 / FPS System Connections

Mount each FPS-3 Dual Zone Pre-Amp processor as shown in Figure 2.

- Use metal brackets or Unistrut-type mounting material to provide a solid backing. A fence post will provide a solid mounting.
- Arrange the conduit/control wiring entrance as shown.
- Install a copper-clad ground rod at each processor location, and connect a minimum 8-gauge ground wire to the processor bolt as shown. **IMPORTANT:** Connect the ground wire directly to the enclosure stud as shown.

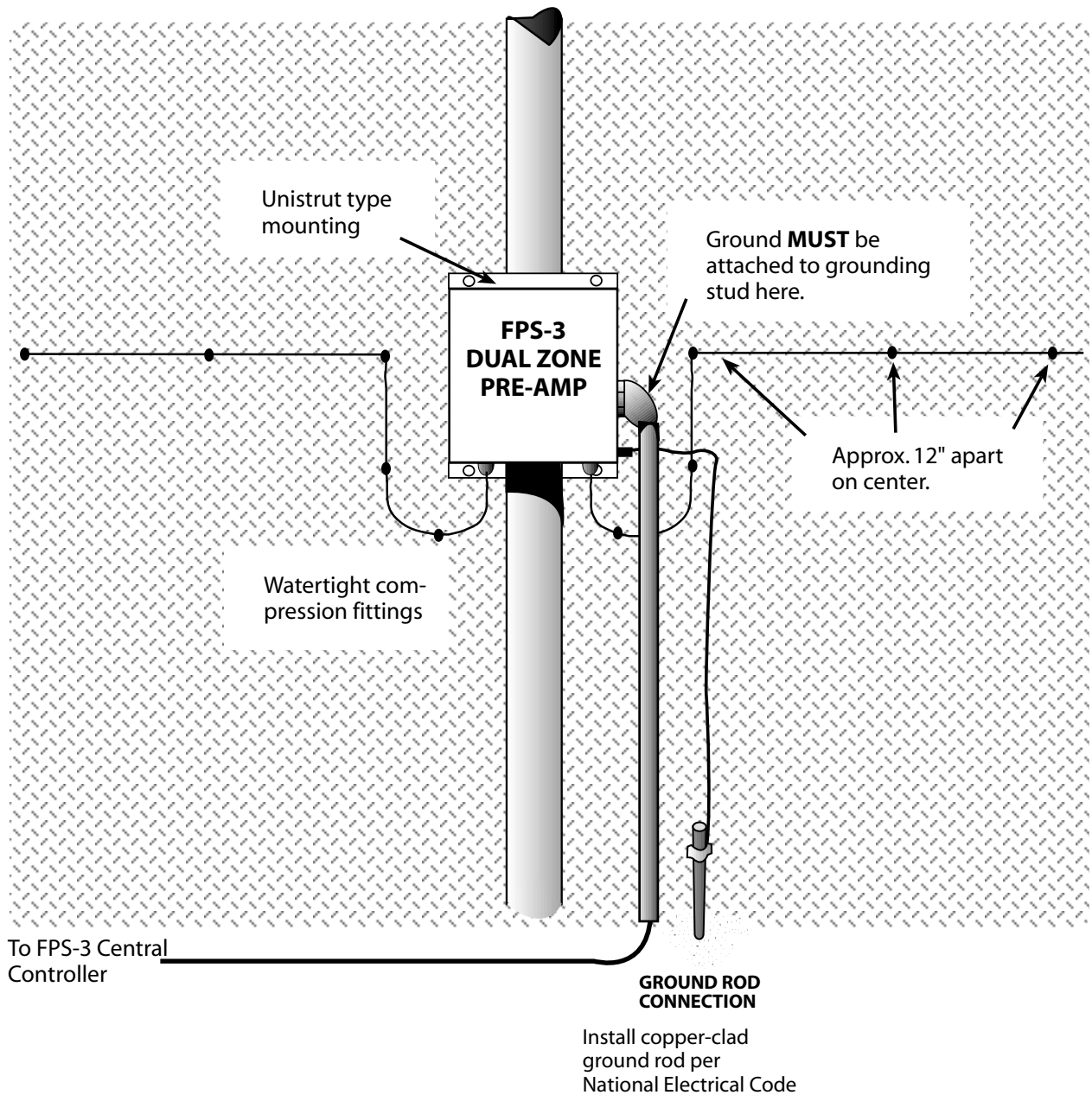

Figure 2. Fence Mounted Dual Zone Pre-Amp

Run the sensor cable from each FPS-3 dual zone pre-amp as shown in Figures 2 and 3.

NOTE: Your installation may utilize either standard "black" sensor cable or Helisensor. Observe special requirements for each type sensor.

- Attach the sensor cable to the fence at approximate 12-inch intervals with black UV cable ties as shown in Figure 3. Use ONLY the approved black UV-protected cable ties.
- Provide service loops every 50 feet and increased sensitivity loops at each corner or end post. Provide cable overlap at adjacent zones. Install TSK termination boxes at each sensor end-of-line (single-run cable) and splices if necessary.
- Connect each sensor cable to the Pre-Amp as shown in Figure 4.
- Connect the control wiring to each dual zone pre-amp as shown in Figure 4.

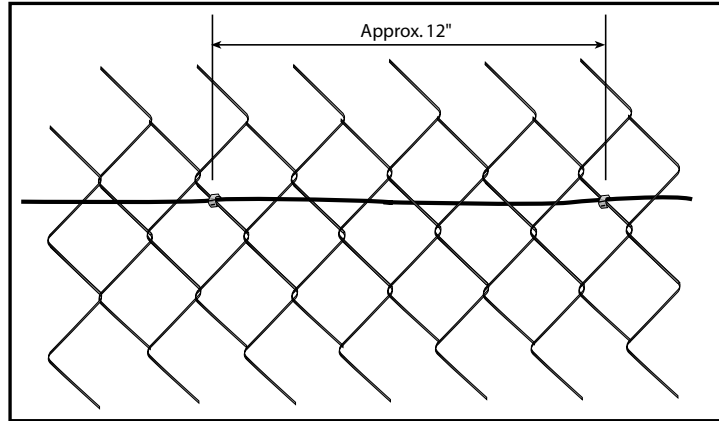

Figure 3. Cable Tie Installation

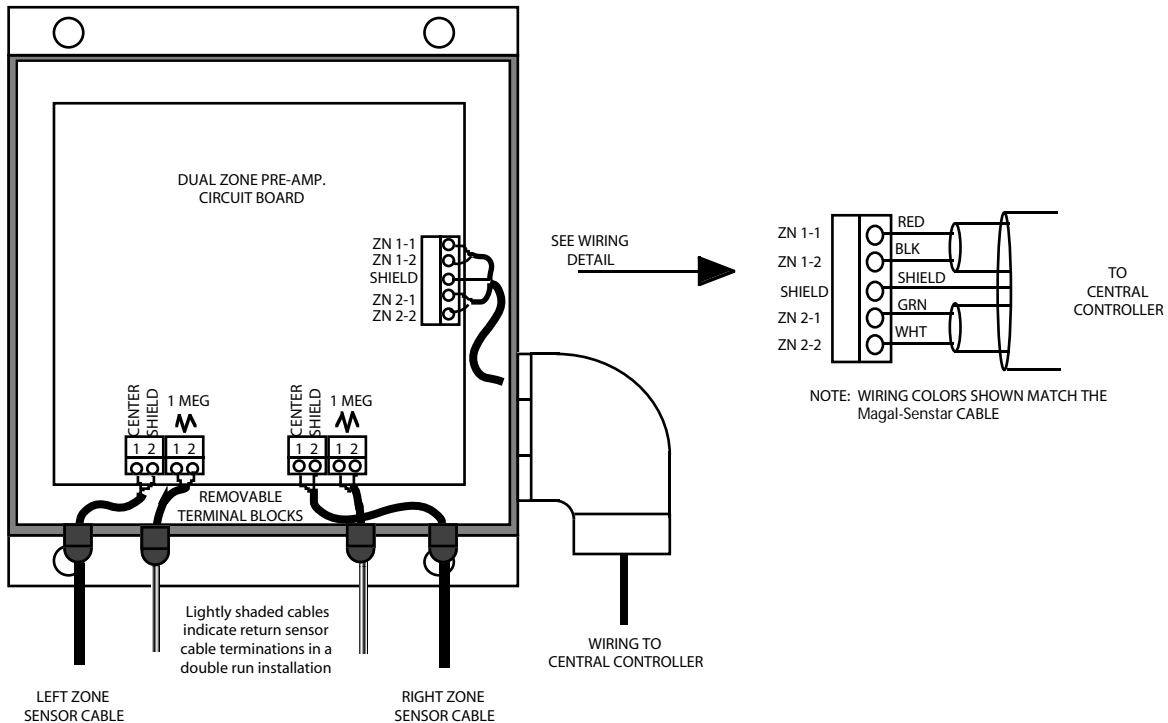

Figure 4. Pre-Amp Cable Connections

Mount each MPS-4100 microwave unit (pair) as shown in Figure 5.

- Install each piece of equipment generally as shown.

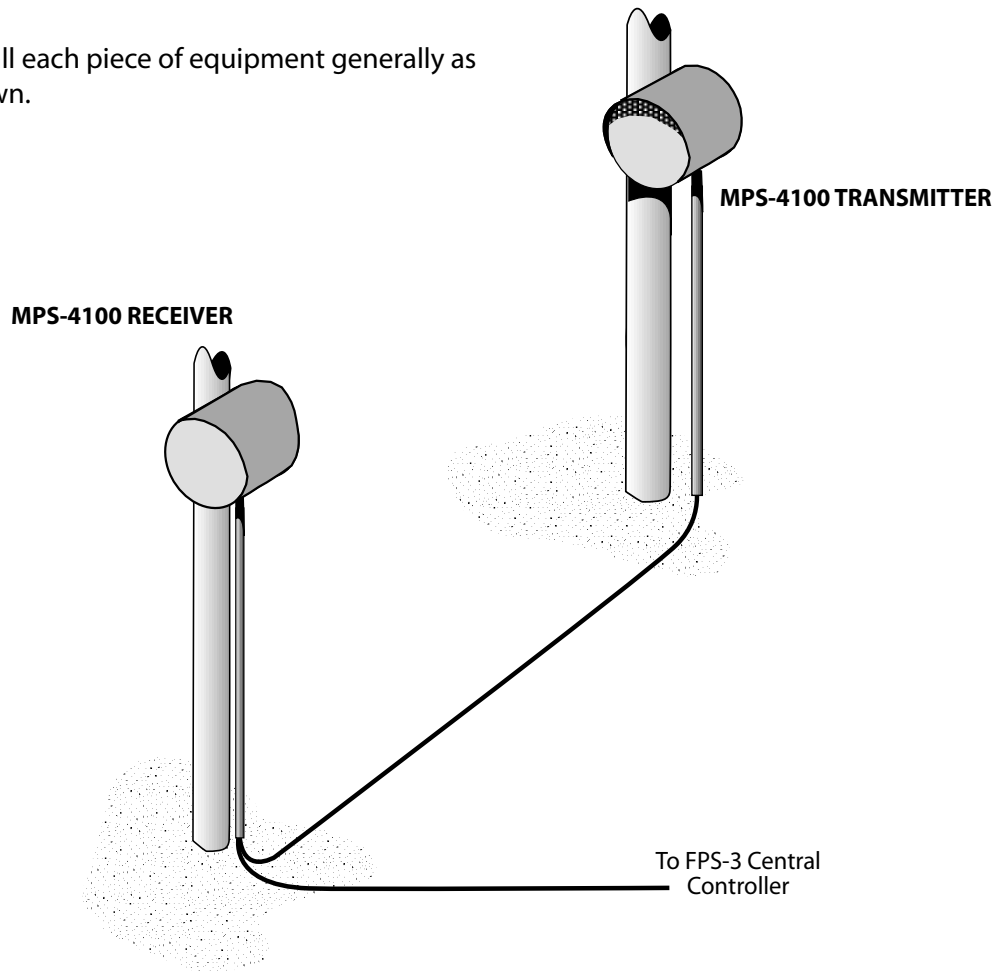

Figure 5. MPS-4100 Microwave Installation

- Run interconnecting cables and connect as shown in Figure 6.

Position the FPS-3 Central Controller and the MX-5300 Control Unit in the control room as appropriate for proper viewing and operation.

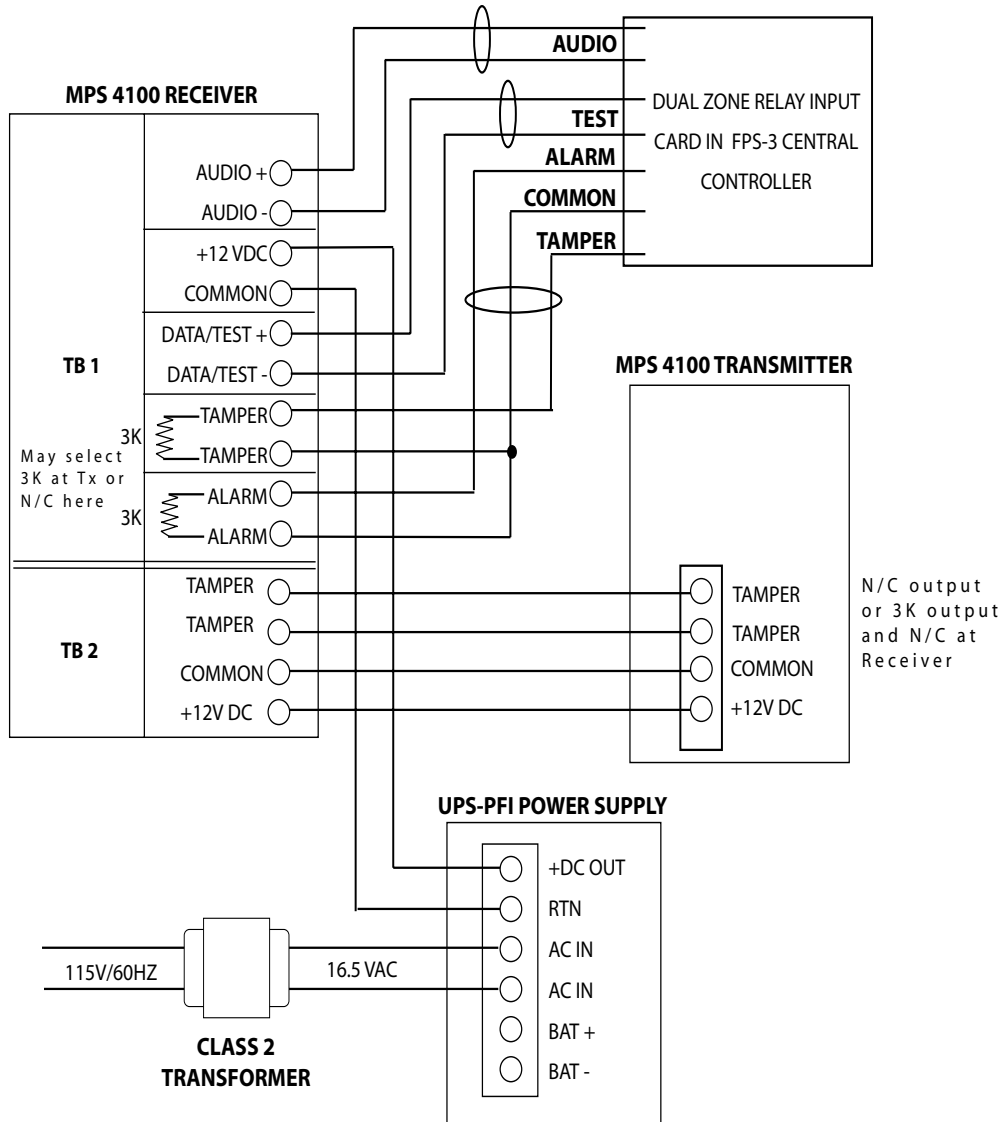

Figure 6. MPS Connections to FPS-3 via Dual Zone Relay Input Card

Connect the power supply transformer and battery as shown in Figure 7.

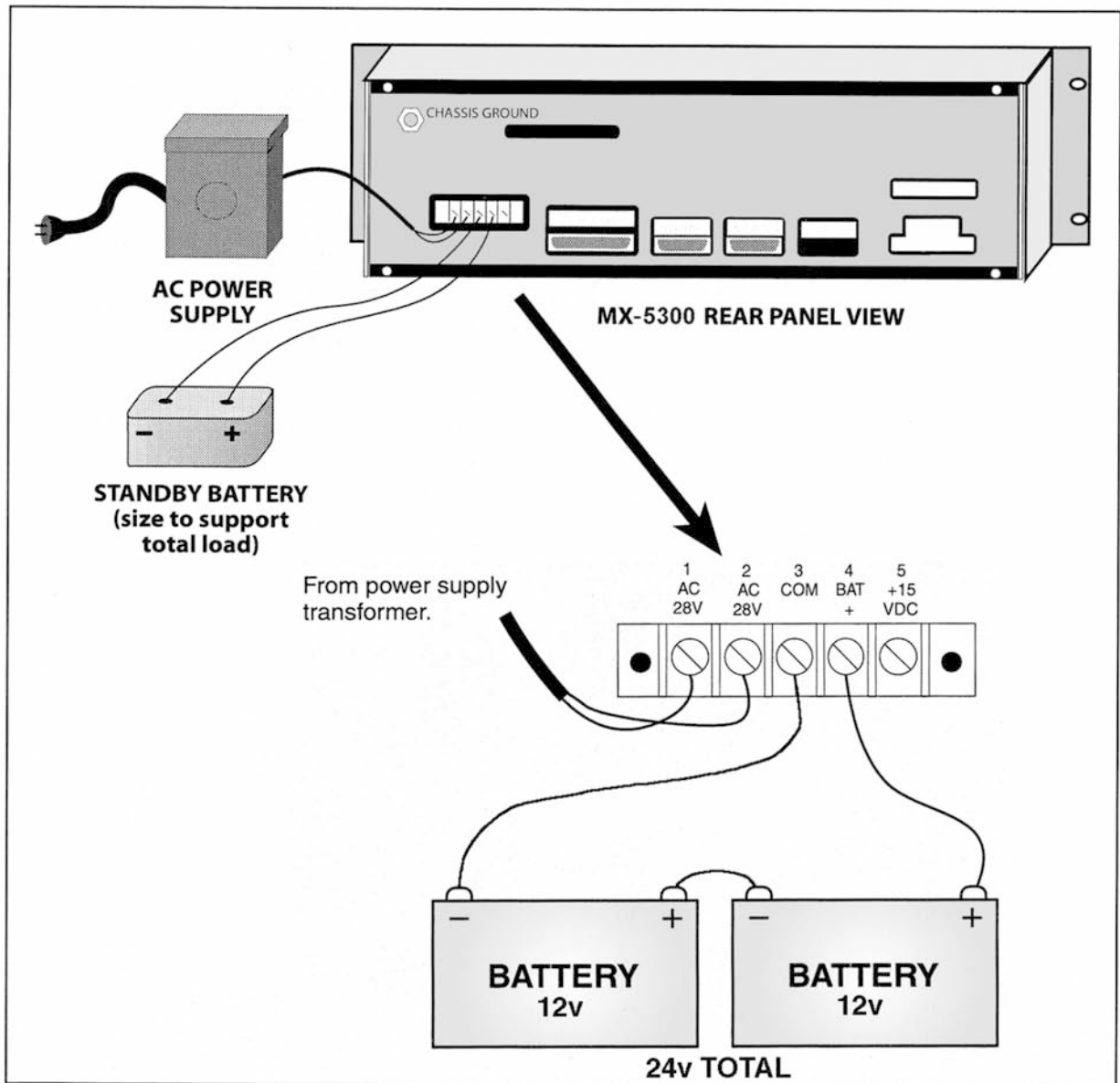

Figure 7. MX-5300 Power Supply Connections

Field wiring connections to the FPS-3 Central Controller will be made as shown in Figure 8.

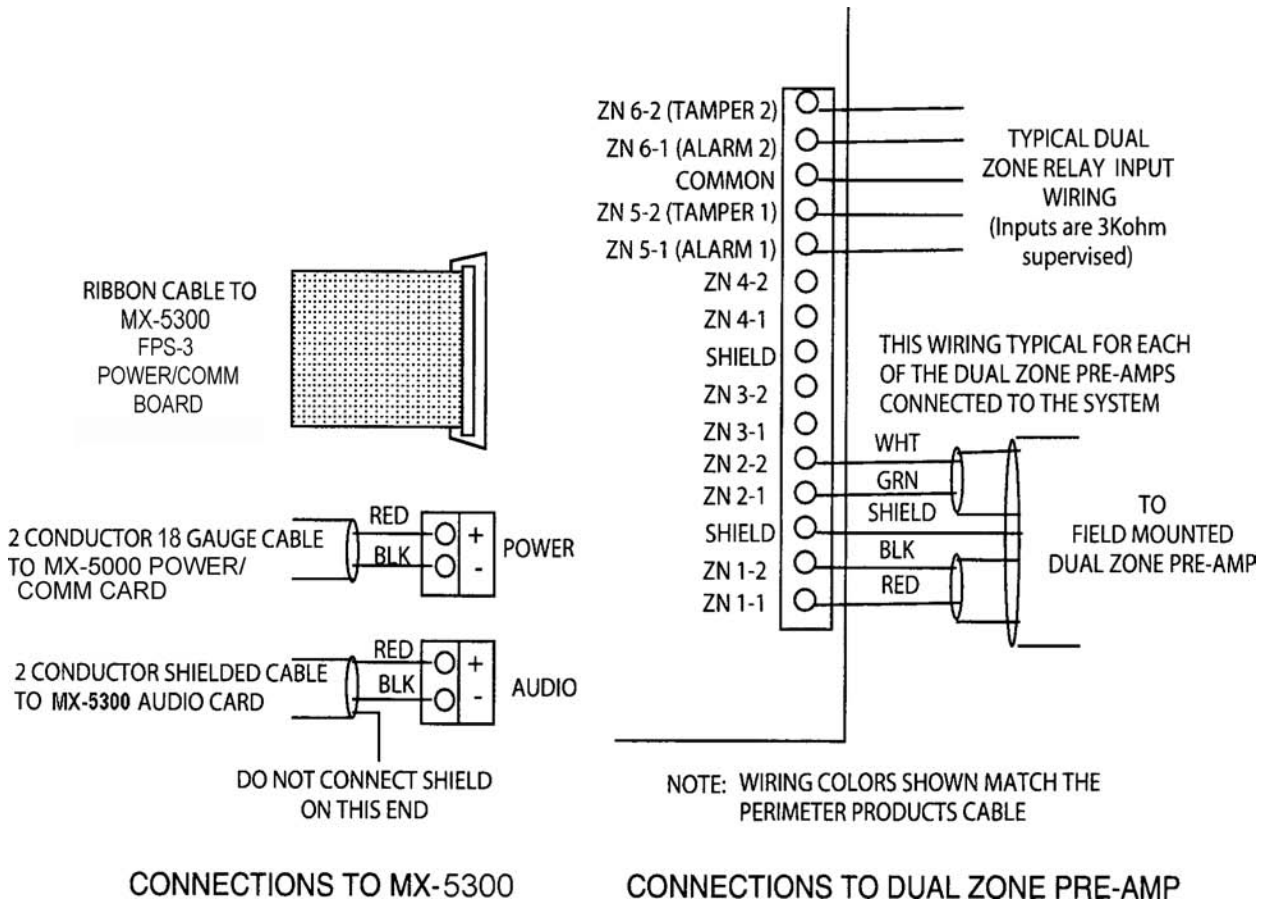

Figure 8. Central Controller Connections

Connections from the FPS-3 Central Controller to the MX-5300 will be made as shown in Figure 9.

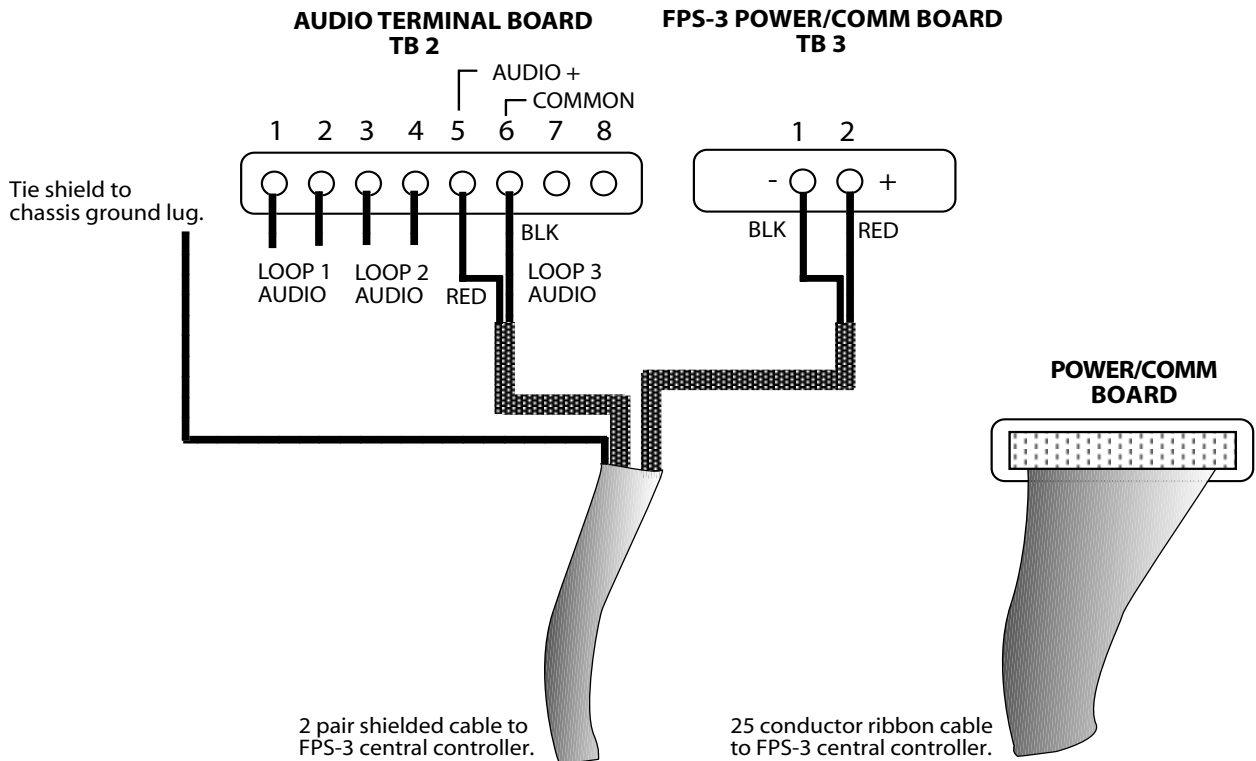

Figure 9. MX-5300 Loop Connections

Apply power to the MX-5300 and FPS-3 Central Controller by connecting the AC power first, then the battery system. Perform initial programming to acknowledge initial alarms.

Perform initial testing of each zone using the self-test function and audio probe of the FPS-3 Central Controller. Measure the optimum gain and count at each dual zone pre-amp using the MSI Field Performance Analyzer (FPA). Perform fence quieting procedure if necessary.

Complete MX-5300 programming by performing the programming steps needed for your system. For programming reference, refer to MX-5300 Installation Manual, Table 2.

Set the FPS-3 dual zone card gain switches for each zone based on your field measurements using the FPA. Program the counts for each zone on the MX-5300.

Perform final testing, including climb test, in each zone as required by the system specifications.

2 GENERAL

Magal-Senstar manufactures a unique outdoor perimeter detection system called the FPS-3 Fence Protection System. The FPS-3 system consists of the fence-mounted transducer sensor cable connected to the fence-mounted dual zone pre-amp and the FPS-3 Central Controller connected to the MX-5300 Command and Display System. See Figure 10. The FPS-3 system is designed for easy installation and maintenance while providing superior detection if someone attempts to climb, lift the fabric or cut through the fence. When the transducer cable is installed on the fence, the transducer cable AND THE FENCE become the fence protection sensor system.

This manual covers all FPS-3 system installations. Just two FPS-3 models are required to accommodate all types of installations:

FPS-3 Dual Zone Pre-Amp is used when installing standard fence mounted transducer sensor cable.

FPS-3H Dual Zone Pre-Amp is used when installing Helisensor cable.

The FPS-3 Central Controller and the MX-5300 Command and Display System are used in all FPS-3 system installations.

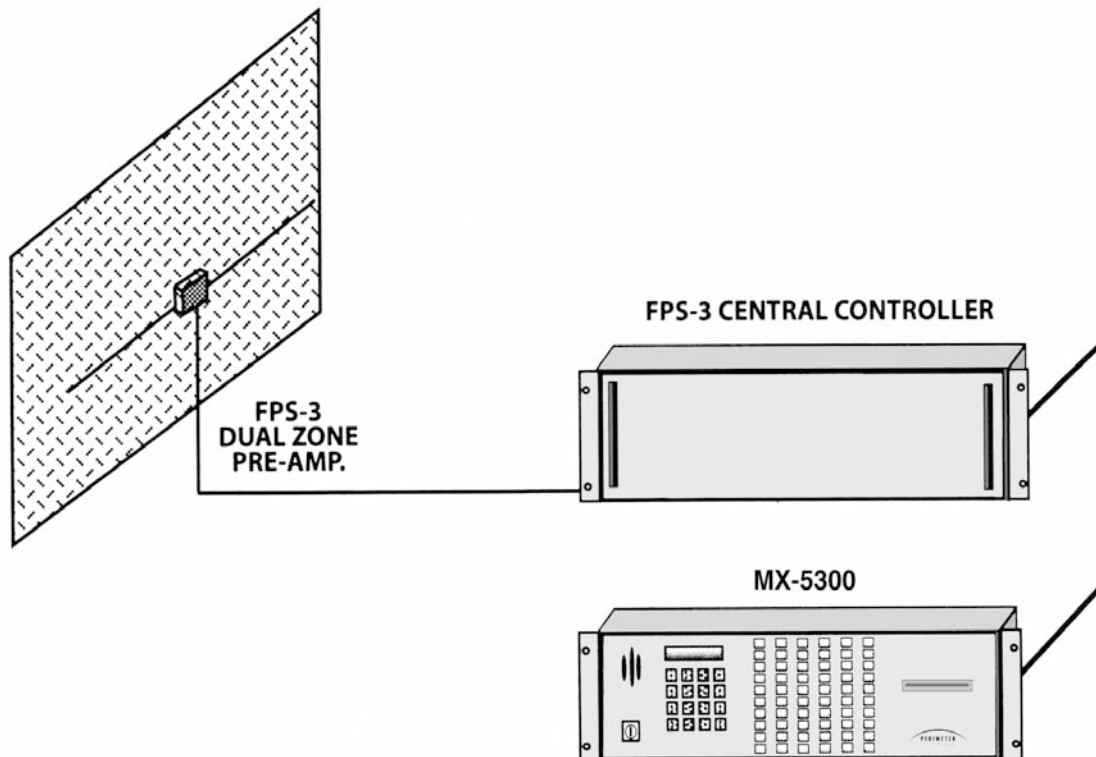

Figure 10. FPS-3 System

3 THEORY OF OPERATION

Concept

When the Transducer Sensor Cable experiences small mechanical shocks or vibrations, an electrical signal is generated between the center conductor and the outer shield. The Signal Processor then analyzes that signal and makes the determination as to whether the vibration is intruder related or from natural causes such as wind, rain, hail, etc. Should there be an intruder, the signal processor will generate an alarm output.

The FPS-3 system features the Magal-Senstar exclusive EDAPT alarm processing system. The EDAPT system utilizes a computer modeling program to analyze the fence activity of all alarm zones and automatically adjust the alarm threshold based on current fence conditions and historical data.

Alarm processing

The MSI FPS system is a strain-sensitive cable sensor system, meaning that a mechanical disturbance in the fence causes a small strain on the sensor cable that is converted to an electrical signal.

The sensor cable is a small coaxial cable specially manufactured with a permanent electrical charge throughout its entire length. Any movement in the fence causes a small voltage to appear at the sensor cable output. Magal-Senstar tests every foot of the sensor cable to verify that the alarm sensitivity will be uniform over the entire length.

The sensor cable connects to the FPS-3 dual zone pre-amp mounted on or near the fence at the beginning of the detection zone. The mechanical disturbance detected by the sensor cable is sent to the dual zone pre-amp. Each FPS-3 dual zone pre-amp contains two independent zones of perimeter protection (see Figure 11). The typical FPS-3 dual zone pre-amp will have up to a 1000-foot alarm zone running in each direction.

1. The dual zone pre-amp sends the alarm and tamper information to the FPS-3 Central Controller for processing. All alarm event processing is accomplished at the FPS-3 Central Controller, away from the harsh outdoor environment of the fence. The Central Controller contains individual plug-in cards for alarm processing, system diagnostic lamps and a built-in test system that allows you to test each zone.
2. The FPS-3 Central Controller forwards alarm event information to the MX-5300 Control Station. The MX-5300 utilizes advanced EDAPT processing, which uses the alarm data in a unique calculation to best determine the occurrence of an actual alarm condition over the external physical forces (wind, rain, etc.) and the aging conditions of the fence installation.

The dual zone pre-amp is capable of monitoring a transducer cable in excess of 1000 feet, depending on the total capacitance of the cable attached to the sensor input. The graph, Table 1, indicates the sensor cable capacitance relative to length. The maximum allowable capacitance is 100,000 pf. In addition to the transducer cable, it is possible to use nonsensitive cable (30MNS) to connect transducer cable to the processor as long as the maximum capacitance is not exceeded. This is sometimes desirable in cases where the processor is not located near the fence.

The ultimate goal of the fence protection system is reliable detection of cutting and/or climbing with minimum nuisance alarms. Since the FPS sensor system is mounted to the fence fabric, care must be taken when installing and maintaining the fence. A fence installed to normal professional standards will provide an acceptable basis for the FPS system. However, a fence improperly installed and/or missing tie wires and clamps can cause nuisance alarms.

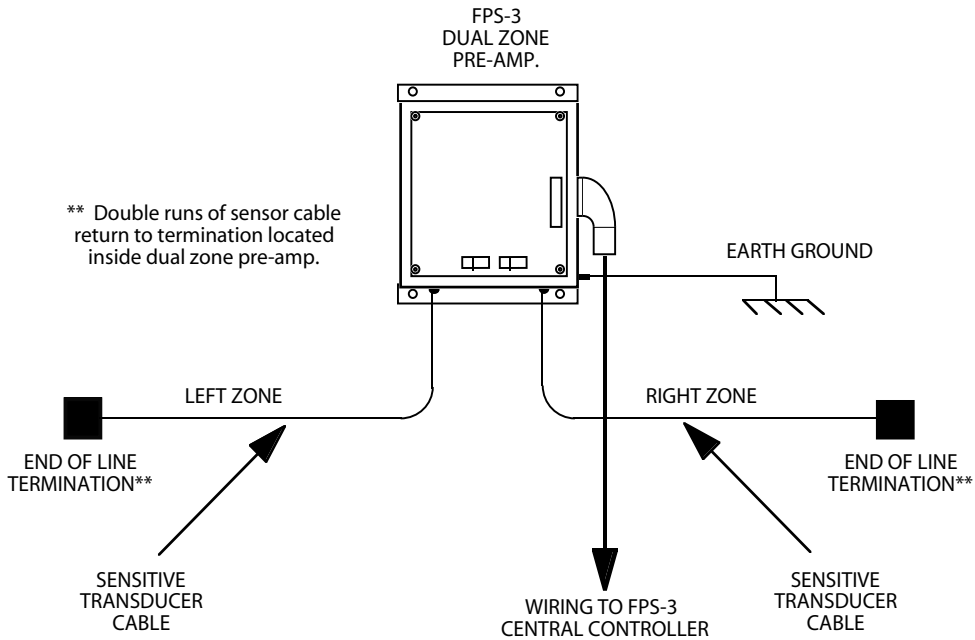

Figure 11. Alarm Zone Connections

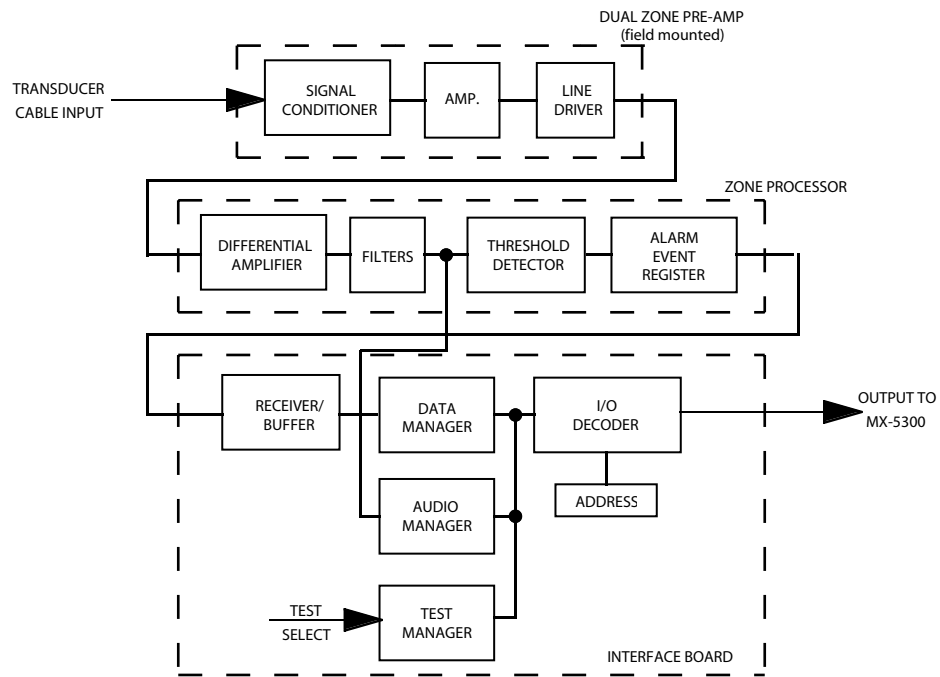

Figure 12. Block Diagram

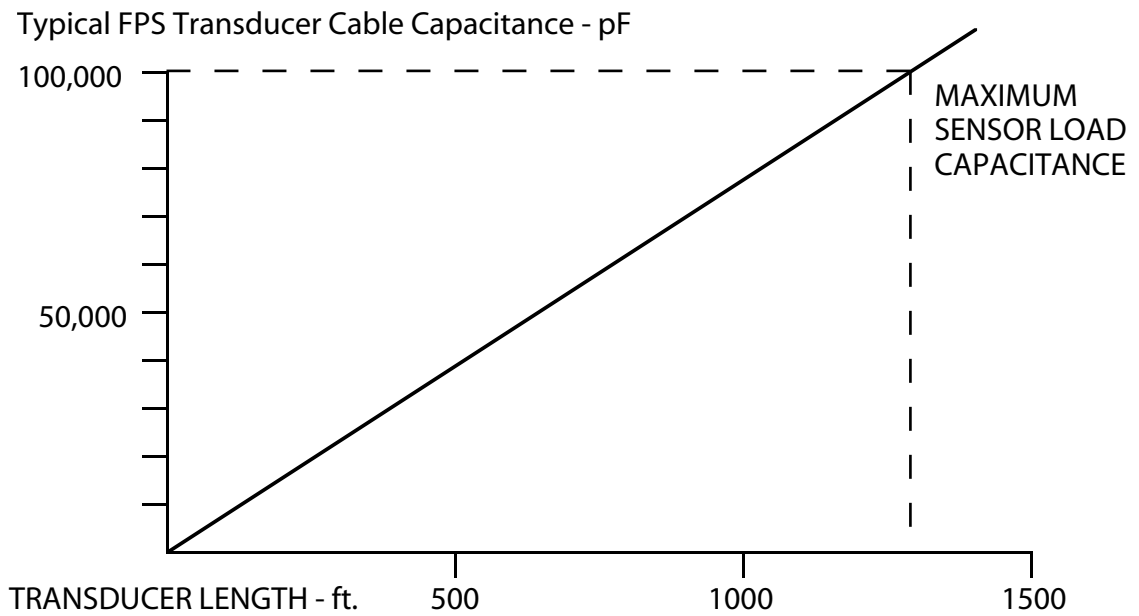

Table 1. Sensor Cable Capacitance

4 FENCE CONDITIONS

Fence Conditions

When the FPS Transducer Sensor Cable is installed on the fence, the sensor cable and the fence become the fence protection system. In effect, the sensor cable listens to the fence to detect the signals caused by climbing, jacking, or cutting the fence.

It is recommended that you walk the entire length of the fence line to determine if the fence requires maintenance prior to installation. Grab the fabric between each and every line post, pull it to you, and let it go. Listen to it! The fence can flex, but if you hear any bangs, clangs, etc., they can be a source of nuisance alarms and should be corrected. Keep a log of any potential problems so they can be identified and repaired before the fence protection system is operational. Refer to Fence Quieting later in this section.

Typical Source or Locations of Trouble Spots

The following photographs (Figures 13 through 22) show examples of the most common problems found with fence installations.



Figure 13 Loose fabric at fence posts or horizontal rails



Figure 14 Loose fabric at diagonal stiffeners



Figure 15 Loose fabric or clamp rings at steel wire stiffeners



Figure 16 Barbed wire dangling due to missing keepers



Figure 17 Mounting pole brackets for barbed wire, concertina or razor ribbon not properly secured to the fence posts

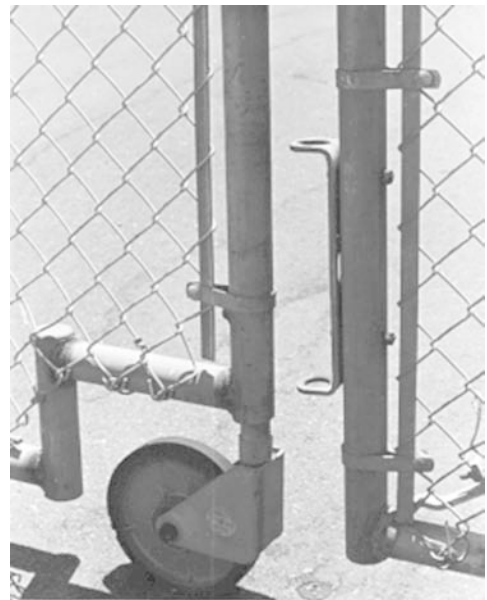

Figure 18 Missing vertical locking posts



Figure 19 Excessive play between locking posts and metal insert



Figure 20 Chain and lock free to vibrate against gate



Figure 21 Too much play between rollers and rails



Figure 22 Signs and/or foreign objects not securely attached to the fence fabric or posts

Additional Sources of Nuisance Alarms

Further inspection may disclose some of the following conditions that may need correcting:

- ▷ Cables, pipes, wires, other fences, limbs, bushes, flagpoles, etc., that may move in the wind and transfer vibrations to the fence.
- ▷ Normal gate operations during protected hours if there is no gate shunt.
- ▷ Condition of the fabric, i.e., old, rusty, loose, rough, and excessive galvanizing material.

NOTE: Spending the time and attention on the fence conditions noted above will result in an efficient and reliable system. Ignoring these sources of nuisance alarms will result in call backs and poor system performance.

Fence Quieting

Section 2 states that once the FPS system is installed on the fence, the FPS and the fence become the alarm system. Therefore, noises generated on the fence can be a major cause of nuisance alarms. However, they do not have to be.

During transducer cable installation, while the work crew is walking the entire length of the perimeter fence, some simple fence quieting action will usually make the operational testing and system check-out go more smoothly.

Major defects in a fence installation will cause fence alarm problems. The major problems should be corrected by a fence contractor. But there are many small problems that can be quickly corrected using your ear, eye, and some black ultraviolet resistant cable ties. Proceed as follows:

- Step 1. Walking the perimeter fence, grab the fence fabric in the center of each fence section. Pull the fence fabric toward you as far as practical and let go.
- Step 2. Listen for noises that sound like metal hitting metal. Typical sounds are clanging, ticking, tapping, etc. The metal-to-metal sounds could be interpreted as counts by the FPS system.
- Step 3. Carefully observe where these noises are coming from. Undoubtedly, a loose piece of metal, a loose fence tie, an improperly tied stiffener, etc., is causing the problem.
- Step 4. Tie the loose item in place using the cable ties. Continue to tie off the noise makers until the fence section is quiet. Continue quieting the fence until all fence panels are quiet.

5 INSTALLATION

General

Installation of the FPS-3 system consists of a systematic installation of dual zone pre-amps, transducer cable, special fence protection units, such as gate protection, and connection to the FPS-3 Central Controller.

In general, the installation should proceed as follows:

- Step 1 Location and installation of dual zone pre-amps.
- Step 2 Installation of sensor cable on fence.
- Step 3 Installation of Telegates or other special gate conditions.
- Step 4 Connection to Central Controller and MX-5300.
- Step 5 Initial testing and adjustment.
- Step 6 Final Testing.

Pre-amp Mounting

Once the Fence Protection System has been designed, the approximate location of each dual zone pre-amp is known. Walking the fence line will allow you to identify the exact location and mounting of each unit.

The dual zone pre-amps are housed in a moisture proof, EMI and RFI resistant enclosure that may be directly mounted to a fence post. It is important that the pre-amp be mounted with the connectors facing down to prevent moisture penetration.

NOTE: For maximum lightning protection and system noise reduction, each pre-amp MUST be grounded to a ground rod at the fence, using the 1/4-20 stud located on the pre-amp housing. Ground rods should be installed in accordance with the National Electrical Code.

On-Fence Mounting

In most cases, each dual zone pre-amp is mounted directly to the non-threat side of the fence. See Figure 23.

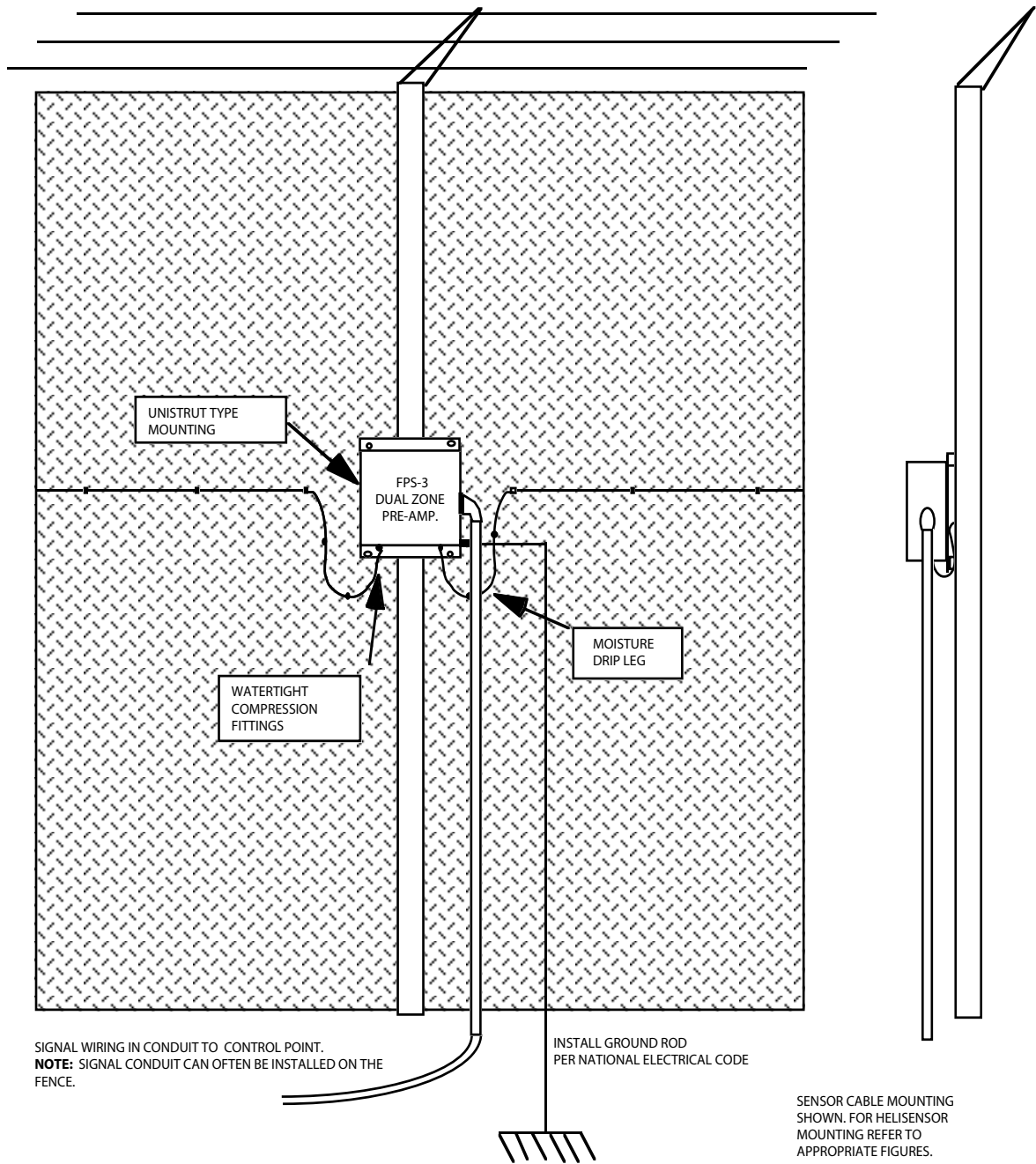

Figure 23. Fence-mounted Pre-amp

When mounting to a fence post, proceed as follows:

- ▷ Fabricate or purchase two pieces of Unistrut or similar bar-type material, for each pre-amp location. The Unistrut should be sufficient length for the pre-amp enclosure as shown. The Unistrut or similar metal should have holes to match the rear mounting holes on the pre-amp.
- ▷ Fabricate or purchase Unistrut or similar pipe clamps to match the size of the fence post. Note that the Unistrut pipe clamps are designed to slide into the Unistrut channel.
- ▷ Assemble the Unistrut pieces into the enclosures before attaching the Unistrut to the fence post. This may best be accomplished in your shop.
- ▷ Mount the pre-amp before extending the signaling conduit to the unit.

If you are installing Helisensor, the pre-amp enclosure will have flex conduit fittings for connecting the Helisensor sensor cables. Connect the Helisensor directly to the processor enclosure using the conduit fittings provided and then connect each sensor cable to the proper terminals as shown later in this manual.

Pedestal or Wall Mounting

In certain instances, it is desirable to mount the pre-amps away from the fence line or at some remote location (i.e., inside a building, in an overhead crawl space, etc.). Installing pre-amps at a remote location can be accomplished using a nonsensitized coaxial cable between the remotely located pre-amp and the fence-mounted transducer cable. The nonsensitive cable eliminates nuisance alarms that could be caused by the transducer cable connecting the two locations. The length of nonsensitive cable that can be used is controlled by the total capacitance of the sensor cable and nonsensitive cable as described in the Theory of Operation Section.

Two example installations are shown in Figures 24 and 25. Remote pre-amp operation is not degraded as long as the total combined cable capacitance does not exceed 100,000 pf. Therefore, the pre-amp should be placed within a wiring distance of not more than 100 feet from the fence.

NOTE: For best results, use only the MSI Nonsensitive cable (Part No. 30MNS) between the pre-amp location and the fence-mounted sensor cable. Cable with a Teflon dielectric may be microphonic and must not be used.

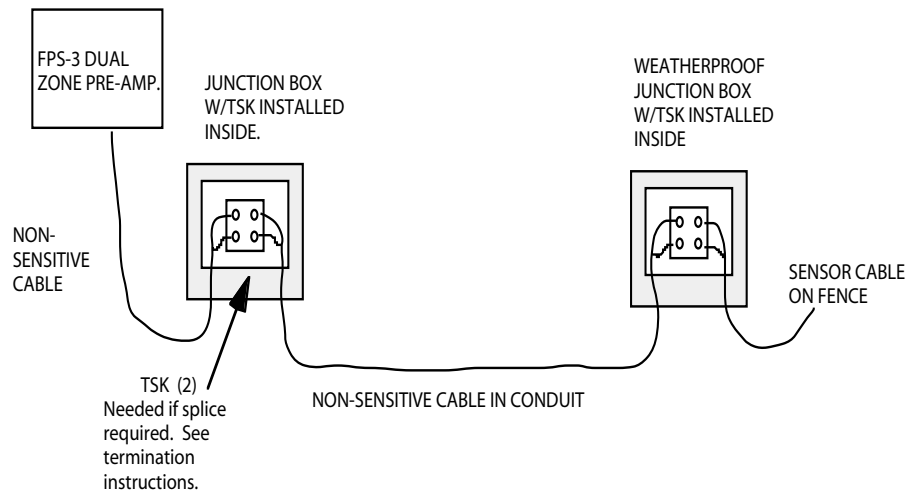
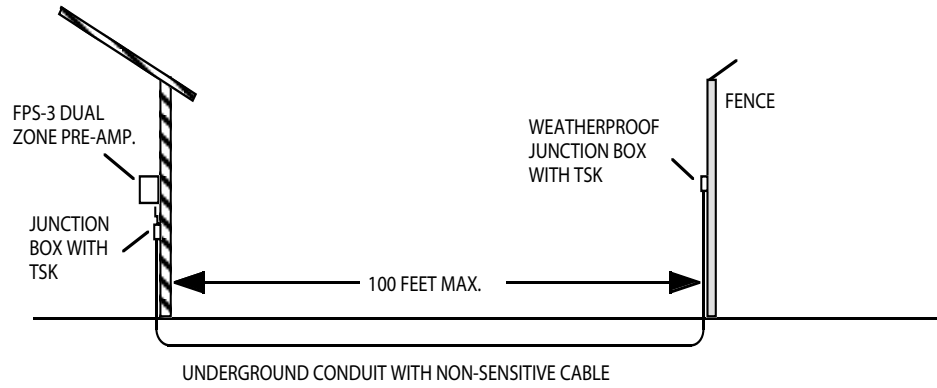

Figure 24. Pre-amp Remote Mounting

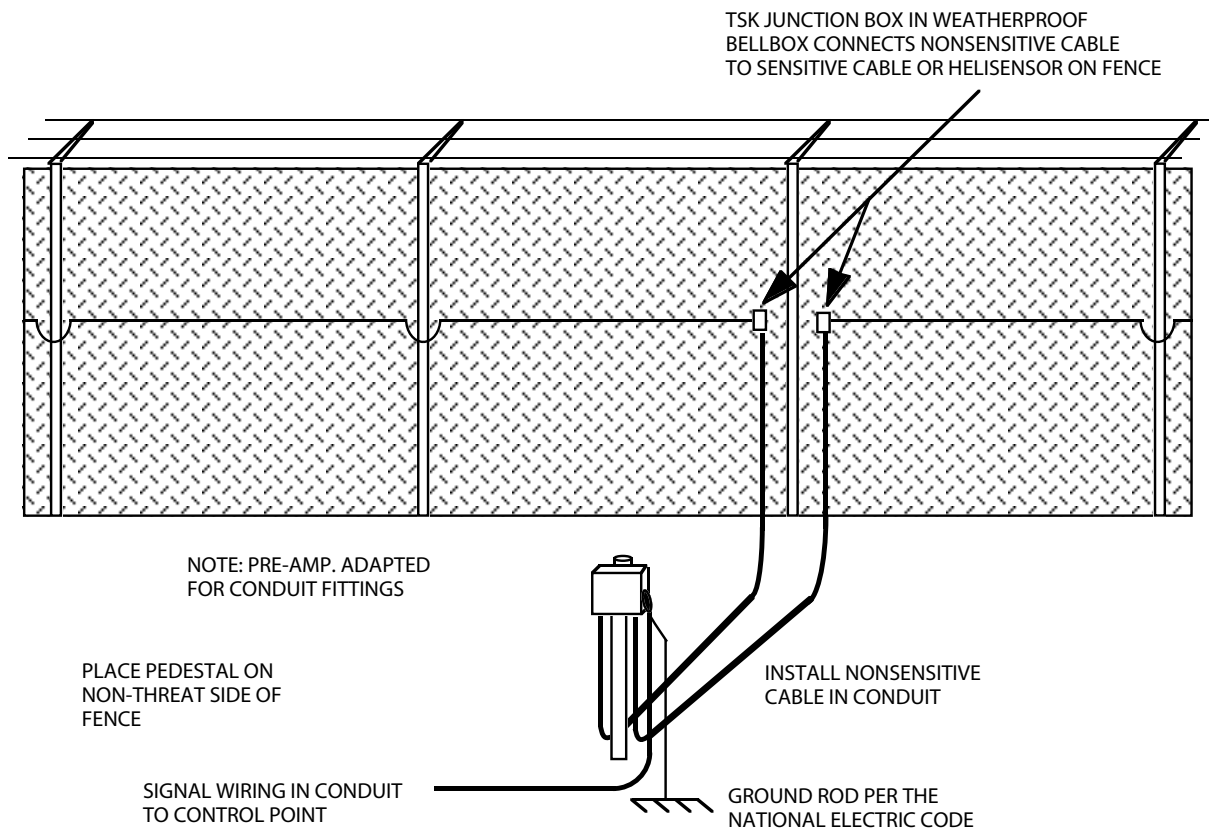

Figure 25. Pre-amp Pedestal Mounting

Transducer Cable Installation

Installation of Standard Coaxial Transducer Cable

Installation of the standard coaxial transducer cable is best accomplished with a minimum of two people; one person to unreel the cable (see Figure 26) while the second person attaches the cable to the fence. If the transducer cable must be installed by only one person, the procedure will be slower. The transducer cable **MUST** be unrolled from the roll so that there are no kinks or spirals when the cable is installed on the fence.



Figure 26. Unreeling Cable

CAUTION: Extreme care should be used when handling the transducer cable as nicking or scraping the outer jacket, and kinking or knotting the cable will shorten the operational life and permit unwanted interference to enter the pre-amp.

The transducer cable should be left with enough length at the pre-amp for a service loop to be used as a moisture drip leg. See Figure 23. The cable should be attached to the fence in a position 3-6 feet high. This height is chosen to prevent dogs or small animals from damaging the cable and to prevent possible damage by grass fires. Sensitivity is best if the transducer is not installed close to horizontal fence stiffeners.

Cable ties should be located at approximate 12-inch intervals. The transducer cable should be installed taut enough to prevent movement in the wind, and yet not stretched to a point where excessive strain will be placed on the cable as the fence is stressed. This can normally be accomplished by pulling the transducer cable just snug as the plastic cable ties are being installed. See Figure 27.

Typically, a 10-foot high fence requires a single horizontal run of sensor cable. Fences higher than 10 feet require two horizontal runs of cable mounted at 4-5 feet and 8-10 feet.



Figure 27. Cable Tie Installation

When the transducer cable is routed from the fence to pass around a fence post or standard and return again to the fence, be sure to leave a slightly loose, but not drooping, loop. Otherwise, when the fence is stressed, the cable can chafe, wearing through the cable jacket.

Example: You should be able to just push a pencil between the fence post and transducer cable.

See Figure 28. If the fence post or standard has a rough or sharp surface, additional insulation must be installed on the transducer cable to prevent damage from long term abrasion. A damaged jacket will permit moisture penetration and allow undesirable interference into the pre-amp. Installation of a spiral wrapped flexible protective material, such as the Panduit 1/8 T12F-0, or similar, is recommended. The protective material must be black weather resistant polyethylene.

Cable ties must not be tightened so tight that the conductor insulation is damaged. To prevent this from occurring, do not use tie wrap Installation tools. Use your hands to draw each tie up until snug.

Care must be taken when installing cable ties to assure the transducer cable is not tied to the fence where sharp metal and/or excess galvanizing material may protrude and damage the cable.

To allow for future transducer cable repair, it is advisable to provide service loops (one foot offsets) approximately every 40 to 50 feet at the fence posts. See Figure 29.

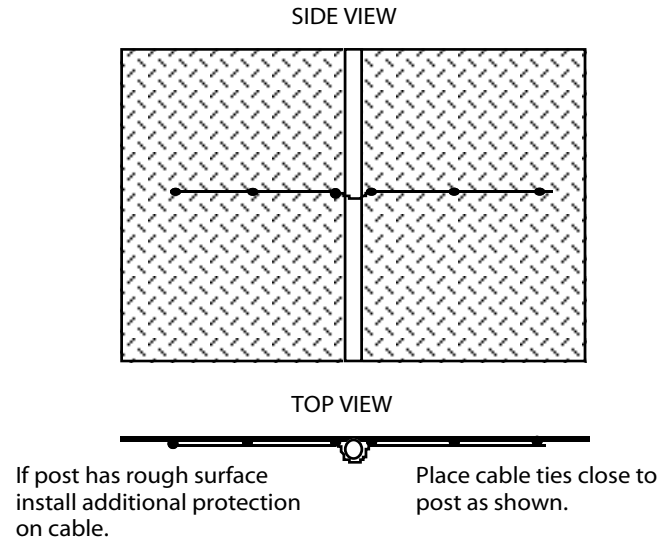

Figure 28. Transducer Cable Around Fence Post

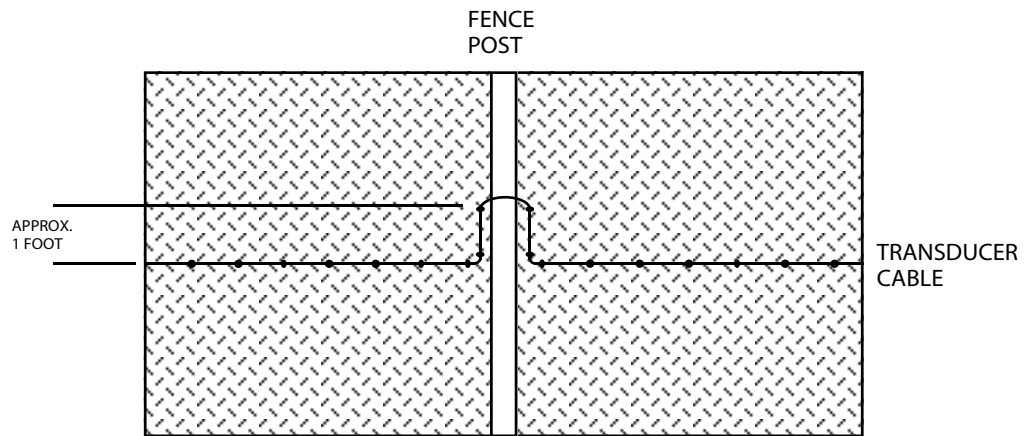

Figure 29. Transducer Cable Service Loop

The fence fabric on either side of a corner post is quite rigid due to both horizontal and diagonal stiffeners. To better ensure detection of a climber, increase the sensitivity by vertically looping the transducer cable several times on either side of the corner post. See Figure 30.

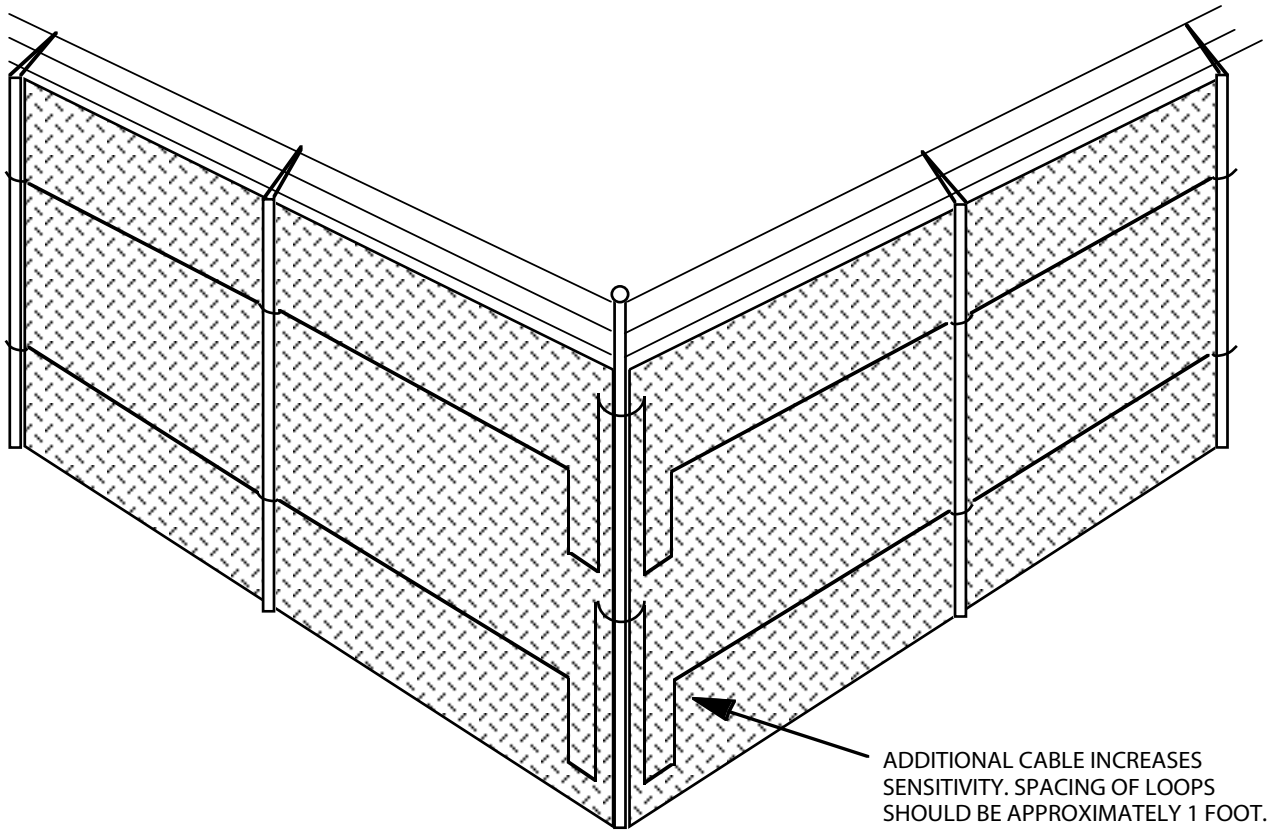

Figure 30. Increasing Transducer Cable Sensitivity

Overlap of adjacent zones is not required but may be desired by some customers. Refer to Figure 31 if overlap is desired. If, at the end of a zone there is an excess of transducer cable, do not coil excess cable as this may become hypersensitive and be the source of nuisance alarms. Cut the cable to the actual length and terminate with the transducer service kit (TSK) and the 1 meg resistor provided. See TSK installation later in this section. Double runs of sensor cable will have both ends terminated in the pre-amp enclosure. See Figure 33.

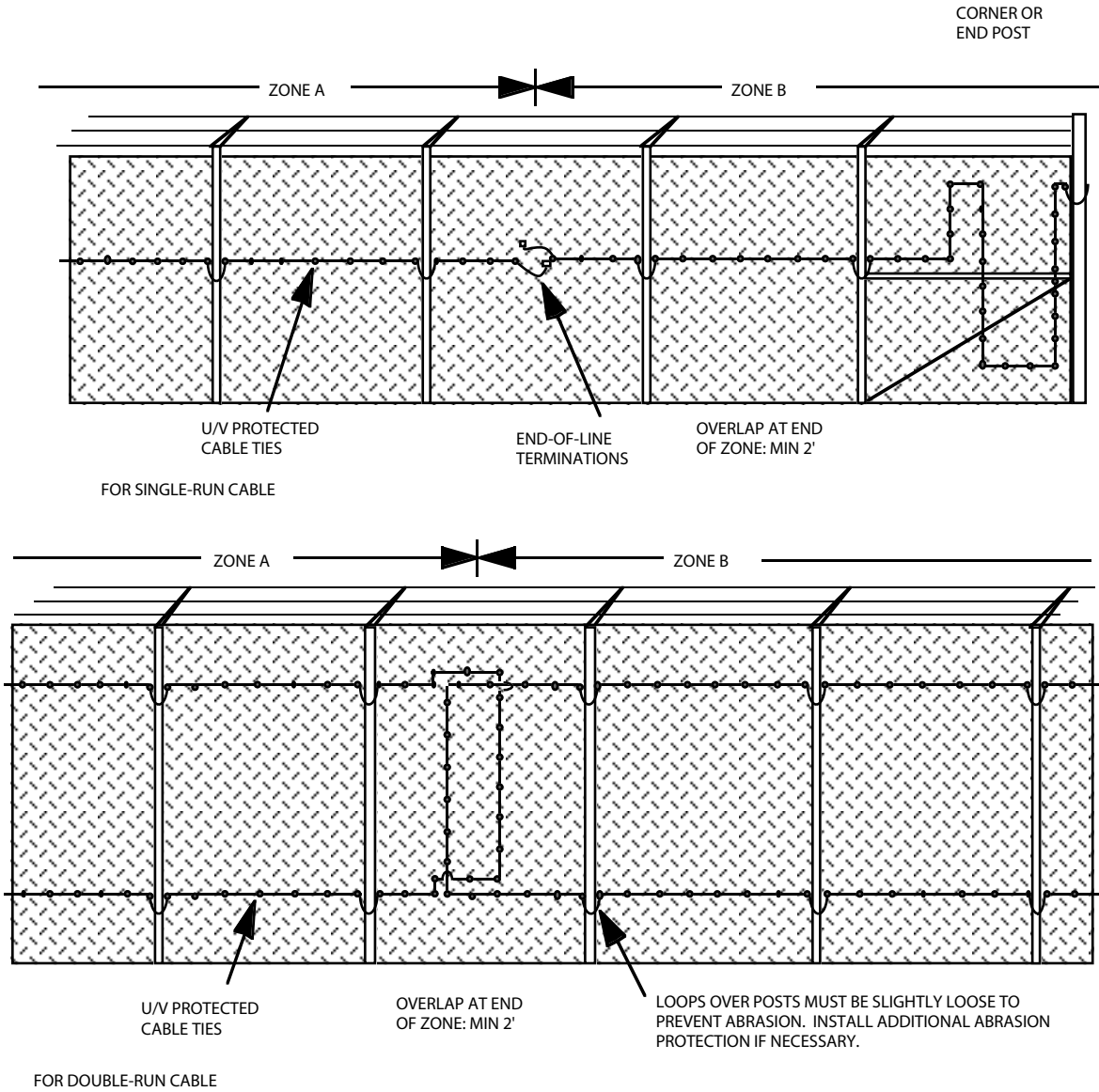

Figure 31. Zone Overlap

Transducer Cable Installation With Two or More Persons

Begin at one end of a zone with one person unrolling the cable and one person loosely tying the cable to the fence. Using cable ties, loosely tie the cable to the fence every 20 to 30 feet to keep it off the ground. Start by leaving a sufficient service loop, then loosely tie the cable at the proper height over the length of the zone. It is best not to cut and terminate the transducer cable until the cable is completely attached to the fence.

Starting at one end of the loosely tied transducer cable (leaving sufficient cable for routing and termination) begin tying the transducer cable to the fence at the approximate 12-inch intervals as shown in Figure 27. Observe special precautions at each post as previously detailed. Continue to the end of the zone and terminate properly. It is recommended that you continue to attach one zone at a time until the entire perimeter is complete.

Transducer Cable Installation With One Person

NOTE: This procedure is not recommended for zones over 100 meters (300 feet) in length.

Start at the beginning of each zone and tie loose (3-inch loop) cable ties at the proper fence height and at intervals of approximately 10 feet. This provides a row of open cable ties that will allow quick threading of the cable to the fence. Place the transducer cable on a suitable cable reel dispenser so the cable will roll directly off the reel with no kinks or knots.

Carefully pull the cable from the reel and thread through the loose ties, one after another, throughout the entire zone length. You must be very careful that the cable does not get caught, scraped or cut. You should periodically check the cable reel and the cable you have pulled through the cable ties. As an alternate to the temporary cable ties for threading the sensor cable, you can make a set of S-hooks from #10 insulated solid wire, such as #10 THHN. The S-hooks should be hung on the fence at 10-15 foot intervals and the sensor cable hung through them. Walk the cable reel along as you place the cable in the hooks. It is recommended that you not string more than 100 feet of sensor cable through the S-hooks at one time.

After threading the cable, begin at one end (leaving sufficient cable for routing and termination) and secure the cable at approximate 12-inch intervals as shown in Figure 27. Observe special precautions at each post as detailed above. Continue to the end of the zone and terminate properly.

Helisensor Transducer Cable Installation

Helisensor transducer cable uses the same FPS fence protection technology, but incorporates a flexible conduit around the coaxial transducer cable to protect from damage or abuse. Helisensor transducer cable is only available in the 100 meter (328 feet) length; however, up to 3 sections can be combined for zone lengths up to 300 meters.

Each length of Helisensor includes a 1/2-inch conduit fitting for attaching to the pre-amp and a conduit with terminations inside. When zone lengths greater than 100 meters are required, the second (or third) length of Helisensor is connected by screwing a 1/2-inch conduit fitting (2nd section) into the conduit (1st section) and terminating the sensor cable to the connector provided in the conduit.

Helisensor can be fastened to the fence fabric using either the conventional ultraviolet resistant plastic cable ties or stainless steel ties. The stainless steel ties can be used where abuse or other damage may result.

NOTE: Do not use ordinary cable ties because they will not withstand the effects of sunlight. MSI provides the proper cable ties with each roll of sensor cable.

The Helisensor installation procedure is very similar to the installation of standard coaxial transducer cable, with added requirements for trimming the zone to size.

Begin by rolling the Helisensor out on the ground alongside the fence. Do not unroll Helisensor in damp or wet areas. Due to the size and weight of the Helisensor cable reels, a suitable cable reel holder is recommended. Lift the Helisensor to the fence and attach at approximate 12-inch intervals using the cable ties furnished. The Helisensor should be pulled straight between the cable ties, but **DO NOT OVERSTRETCH**. The spiral covering must remain flexible or the sensor will not function properly. Allow for extra sensitivity at corner posts (see Figure 30).

In most cases, the zone length will not coincide with the length of the Helisensor so the cable length will have to be adjusted to match the length of the zone. If the zone is longer than 100 meters, connect a second length of Helisensor and continue to the pre-amp end of the zone. If the Helisensor is too long when you reach the pre-amp end, it is best to leave the extra length connected until you have completely tied the Helisensor to the fence at approximate 12-inch intervals. Then cut and terminate the excess Helisensor as detailed below.

The pre-amp end of the Helisensor has a 1/2-inch conduit termination. The dual zone pre-amp enclosure is available with two cable entry configurations: The standard FPS-3 enclosure provides up to four compression fittings for the sensor cable. The optional configuration, FPS-3H (H suffix for Helisensor) has up to four flex conduit fittings in place of the compression fittings. The H configuration allows Helisensor termination directly to the pre-amp enclosure, as shown in Figure 32, and is recommended for new installations. A double run Helisensor should be terminated to the pre-amp enclosure as shown in Figure 33. The enclosure completes the full mechanical protection of the sensor cable.

NOTE: Always install condulets at a 45° angle so that the Helisensor forms a drip loop and prevents moisture from entering the condulet.

Trim the Helisensor to the required length for termination as follows:

- ▷ With the pre-amp installed, measure and mark the Helisensor metal jacket length to mate with the enclosure. Be sure to leave sufficient Helisensor for a drip loop.
- ▷ Using a flexible conduit cutter or a hacksaw, score and break the Helisensor metal jacket making sure you do not cut the transducer cable inside.
- ▷ Remove the excess Helisensor jacket, leaving enough of the black transducer cable to route through the termination box and conduit and to the terminations inside the pre-amp enclosure.
- ▷ Terminate the Helisensor to the enclosure as shown in Figures 32 or 33, using the 1/2-inch conduit termination provided. Helisensor should be attached to 1/2-inch conduit fitting before it is secured to the pre-amp enclosure.
- ▷ Terminate the black transducer cable inside the pre-amp as detailed under Transducer Cable

Connections.

- ▷ Mount each conduit slightly above the line of Helisensor to create a drip loop to prevent moisture buildup at conduit terminations.
- ▷ For remote mounted pre-amps, follow instructions in “Pre-amp Mounting” (page 26) through “Pedestal or Wall Mounting” (page 28) sections (see Figures 24-25) and terminate Helisensor to bell box.

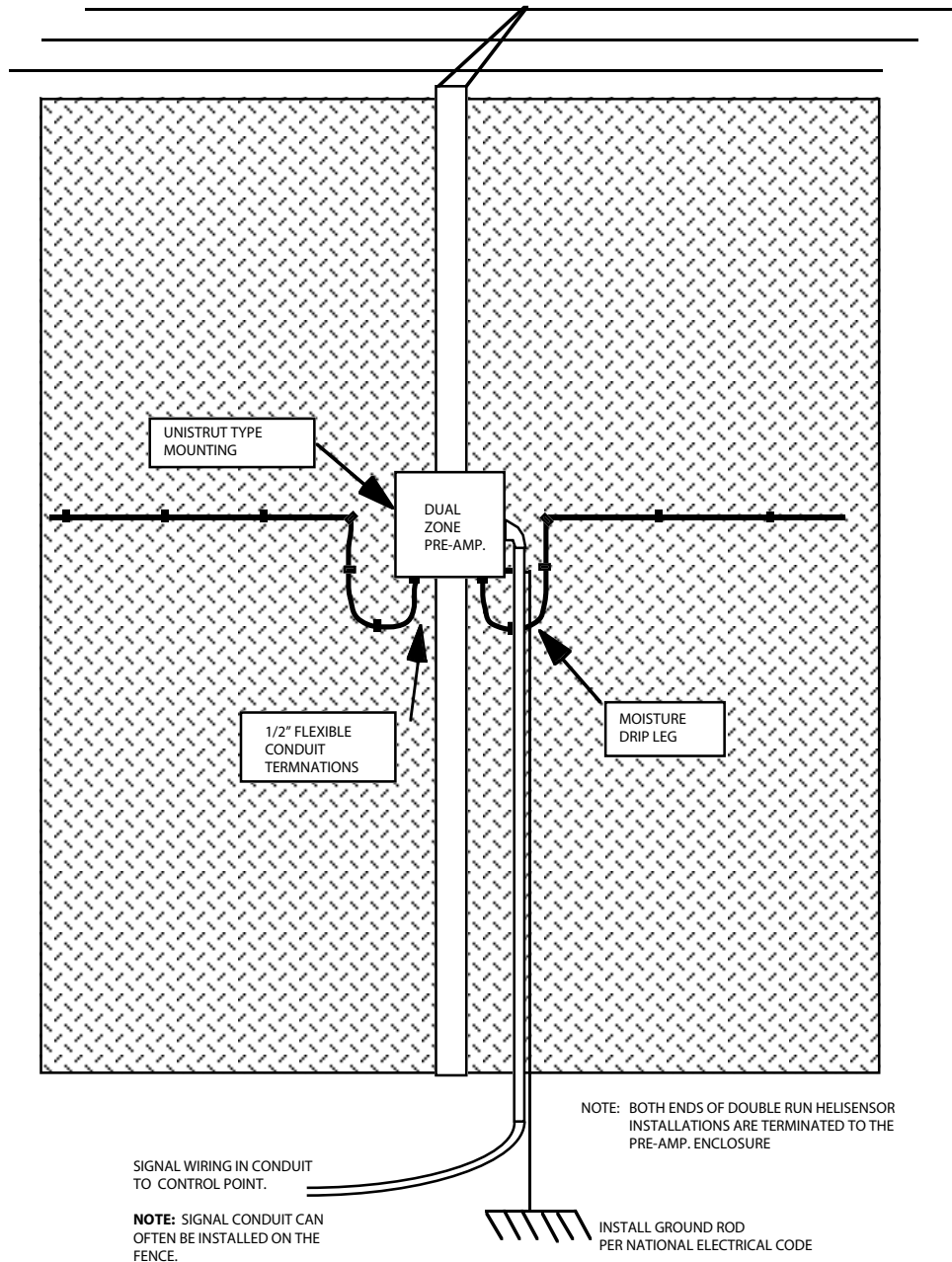

Figure 32. Helisensor/Sensor Cable Termination - Single Run

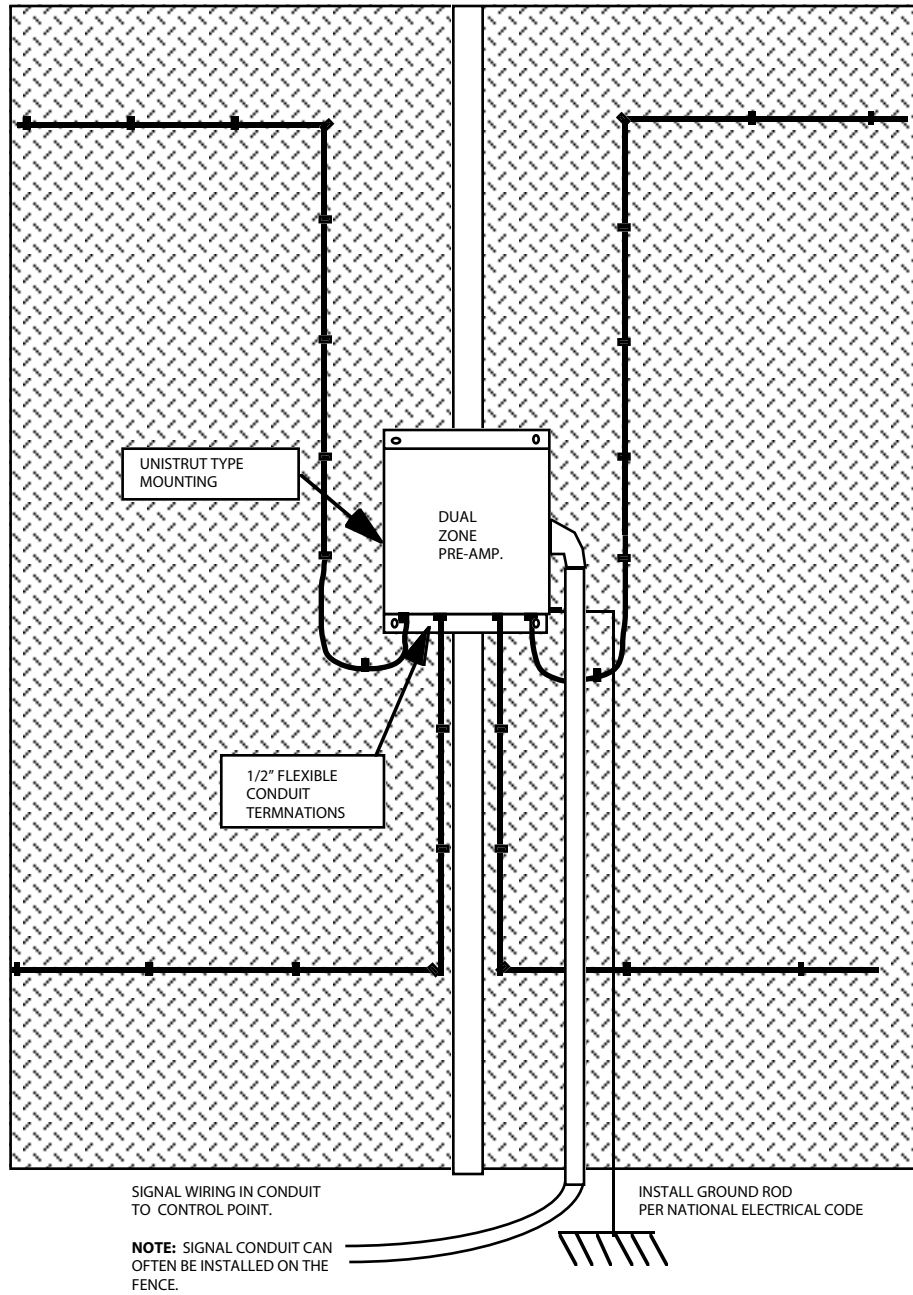

Figure 33. Helisensor/Sensor Cable Double Run Installation/Termination

Condulet Installation

The condulet circuit board has been re-designed with the end-of-line resistors built into the board and conformal coating to prevent moisture in the condulet from shorting the EOL resistors - a common cause of tamper alarms. This Condulet may be used for single or double end-of-line terminations or for splices. It may also be used for supervised "T" tap end-of-line terminations requiring a 2 meg-ohm end-of-line resistor.

1. Open cover and remove circuit board. Note that the circuit board is installed sideways with a plastic shield to insulate the board terminals from the Condulet enclosure. The 4 stand-offs lift the circuit board to prevent moisture accumulation on the board.
2. Clip the required jumpers according to the type of termination. See Figure 36-38.
3. Attach sensor cable(s) to terminal strip(s). Note that the sensor cable entering the left end of the Condulet attaches to the terminals on the right end of the circuit board and vice-versa for the right sensor cable. See Figure 34.
4. Re-insert circuit board sideways making sure that the plastic shield covers the terminals. Replace cover.
5. Condulet should be attached to the fence at a 45 degree angle with the cover facing out as shown. Allow a drip loop as shown to prevent water drainage into the Condulet. Do not position the Condulet with the cover facing up. See Figures 39 and 41.

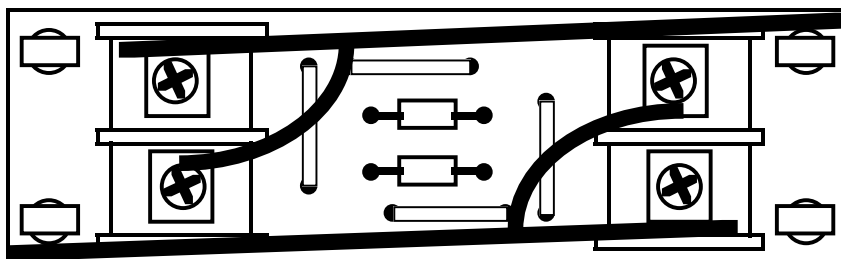

Figure 34. Transducer Cable Routing in Condulet

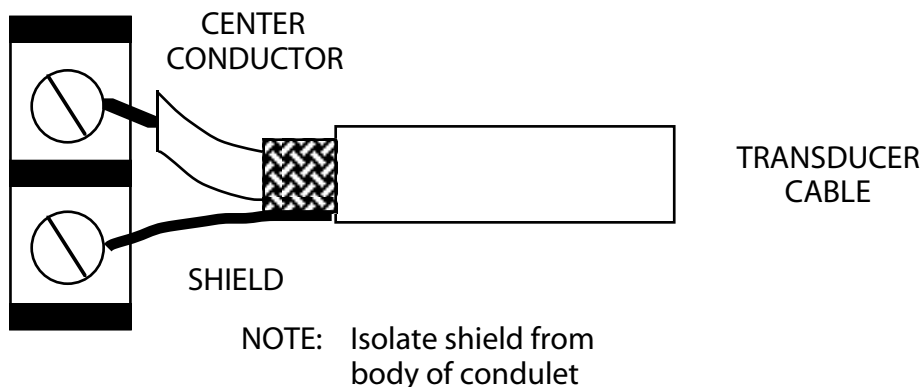

Figure 35. Transducer Cable Connection

For end-of-line termination, attach sensor cable to terminals as shown in Figure 36. Clip jumpers 2 & 4. For double end-of-line terminations, attach sensor cables to both terminals.

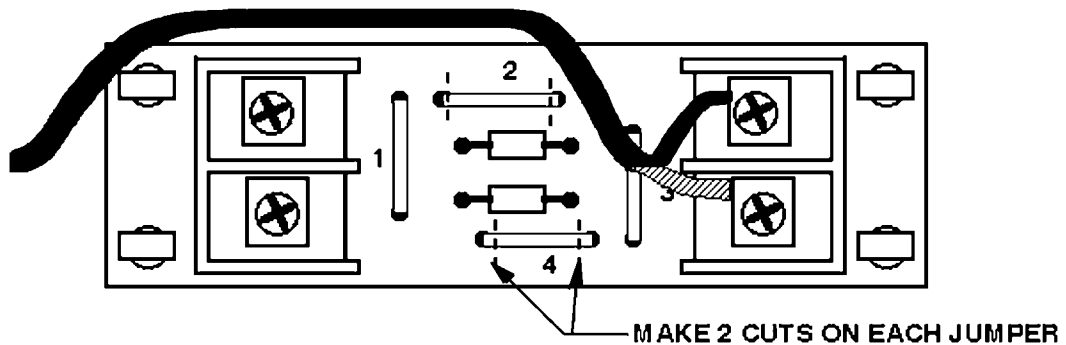

Figure 36. End-of-Line Termination

Helisensor is provided in standard 100 meter lengths. Some applications may require longer zone lengths. The additional length is threaded into the conduit and the transducer cable is connected as shown in Figure 37. Clip jumpers 1 & 3.

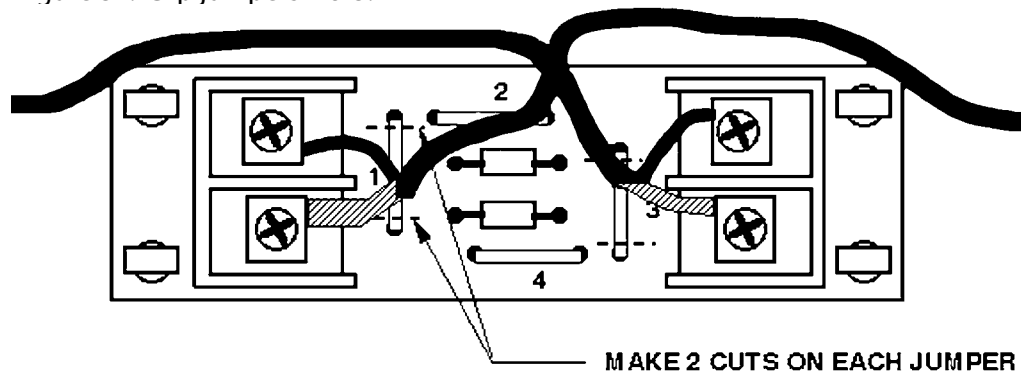

Figure 37. Splice Termination

In cases where the transducer cable is "T" tapped as in applications involving Telegates for gates, it is necessary to provide for supervision of both cables. This requires a 2 megaohm resistor at both the "T" section and the normal end-of-line. Attach the sensor cable as shown in Figure 38 and clip jumper 2.

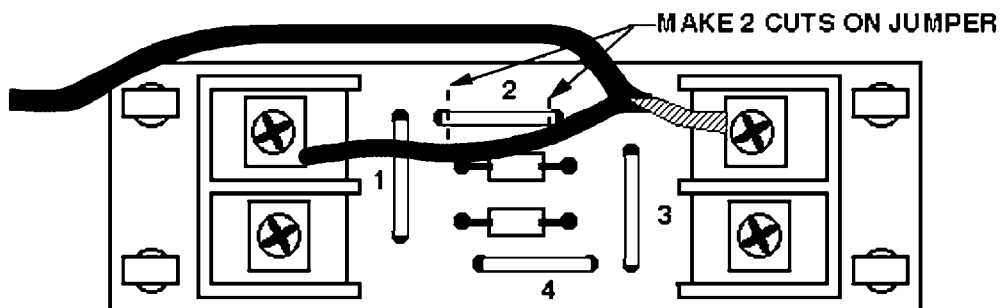

Figure 38. End-of-Line Termination With 2 Megaohm Resistor

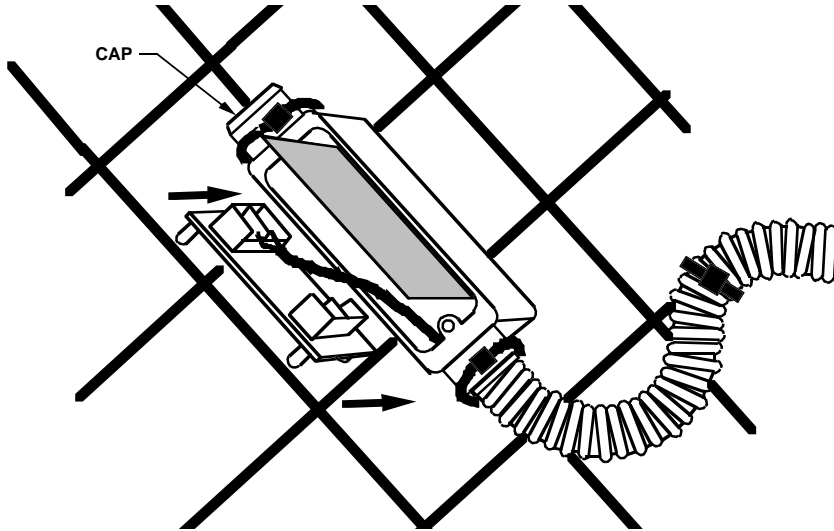

Figure 39. EOL Condulet Attached To Fence

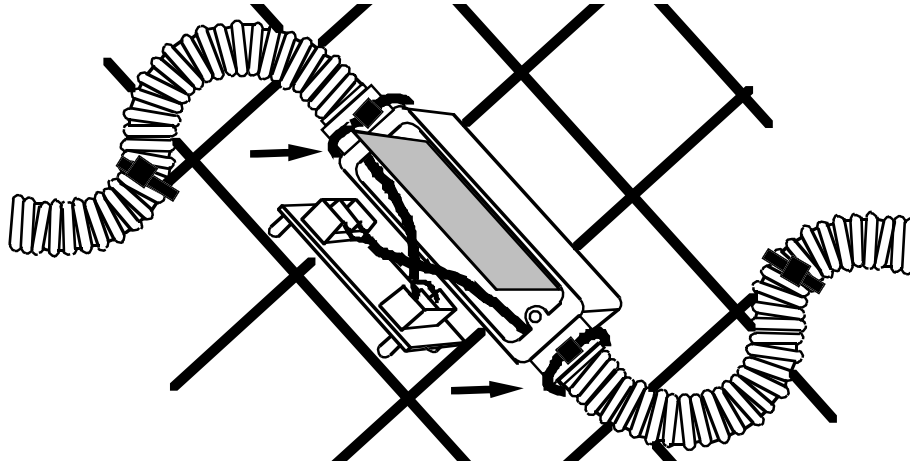

Figure 40. Condulet Splice Attached To Fence

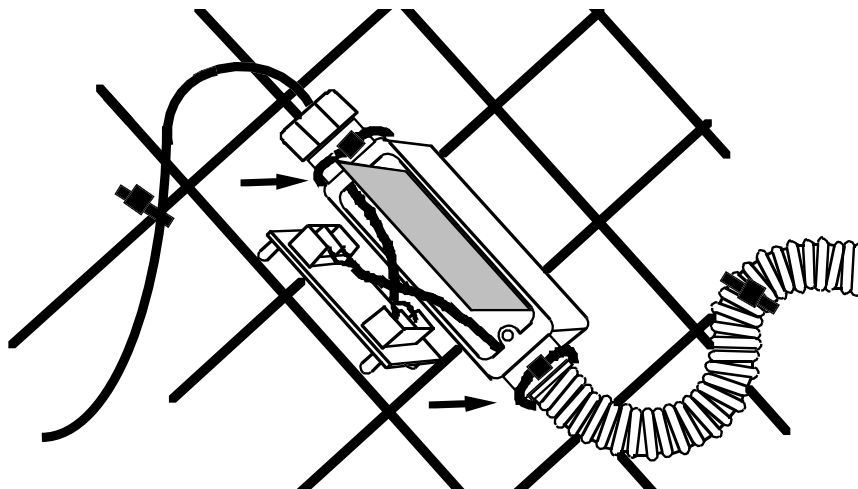

Figure 41. Condulet "G" Attached To Fence

Transducer Service Kit (TSK) Installation

Transducer service kits (TSK) are required for all end of line termination and splicing of standard transducer cable. TSK installation is very important to be sure that moisture does not affect transducer cable operation. When a double run of sensor cable is installed, utilize the end-of-line termination located inside the pre-amp enclosure. A separate TSK is not required.

Each TSK consists of the service kit enclosure, a 1 Megohm, 1% metal film resistor preinstalled on the terminal block, and a cable tie for fastening to the fence fabric. The service kit enclosure is molded of sunlight resistant polymer with a conductive (copper) inner surface to maintain a proper shield around the termination. See Figure 42.

Proper preparation and installation of the transducer cable is essential to provide a water tight seal within the TSK. TSKs must always be installed with the cable entering the bottom. Each cable must have a drip loop so moisture is not allowed to collect near the cable openings. After splicing or termination, each TSK should be filled with Dow Corning 4 electrical insulating compound before sealing. The Dow 4 compound will keep moisture away from the terminations.

The transducer cable shield must be properly stripped and installed to contact the TSK copper shielding saddle on the inside edge of the cable entry. The inner conductor must be trimmed to the proper length to reach the termination screw.

To prepare each end of the transducer cable for TSK termination, proceed as follows:
(Refer to Figure 43.)

- Step 1: Strip outer insulation 1 inch from the end.
- Step 2: Pull braided shielding back 3/4 inch from center conductor and twist for insertion into terminator receptacle.
- Step 3: Strip center conductor insulation back 1/4 inch from the end and insert into one side of terminator receptacle and tighten lock screw.
- Step 4: Insert twisted shield into terminator receptacle next to center conductor and tighten lock screw.

NOTE: Prior to installing service kit cover, ensure the transducer outer insulation fits at the inside edge of the cable saddle on the service kit and that the shield contacts the saddle. This is very important to maintain a proper seal. Insulation too far inside the service kit may hinder closing the top cover and too far out may allow moisture to penetrate the enclosure. This may also interrupt the enclosure shield and allow EMI to enter the system.

- Step 5: If splicing two sections of transducer cable, remove the preinstalled 1 Megohm resistor from the terminal block.
- Step 6: Fill the TSK completely with the Dow Corning 4, or other approved, silicone grease.
- Step 7: Install top cover, being sure it seats on all sides, and attach to the fence with a single cable tie.

CAUTION: Use only factory supplied or 1% metal film EOL resistors. Carbon and other resistors are not stable and must not be used.

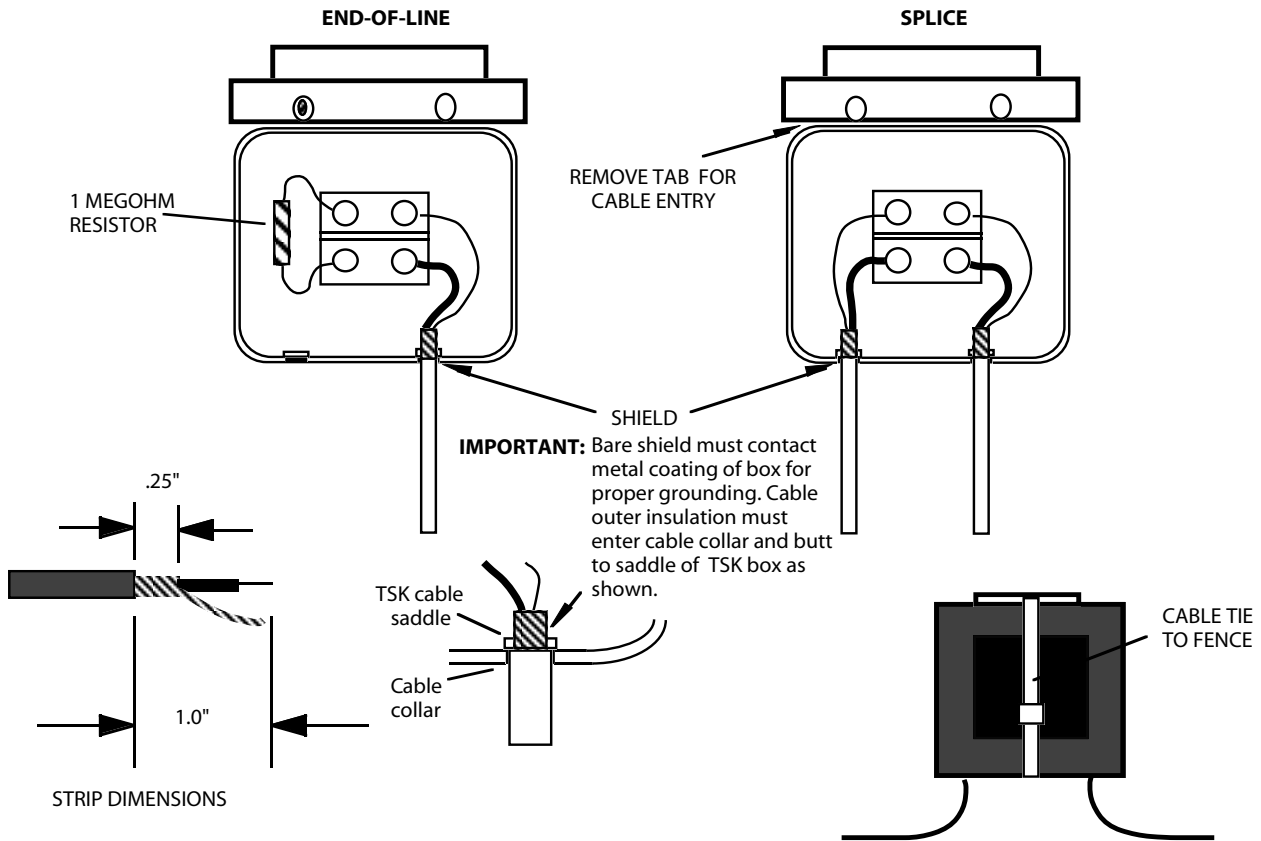

Figure 42. Transducer Service Kit

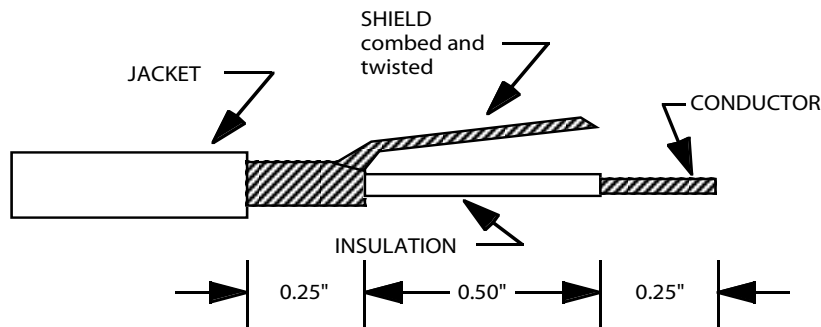

Figure 43. Transducer Cable Preparation

Gate Installations

Gates, including sally ports, require the same protection as the fence. There are many types of gates, but they are generally swinging or sliding. Additionally, gates can be installed as either single or double gates. Normally, gates are manufactured from the same fabric as the fence so the FPS transducer cable will provide the same level of protection.

Hinged (swinging) gates that are seldom used, such as gates used for maintenance, can usually be protected with transducer cable. High usage hinged gates can be protected in the same way but should probably be assigned their own alarm zone. Sliding gates are best protected using a Telegate. Gate areas may also be protected using a non fence-mounted sensor such as the MPS-4100 microwave system.

Swing Gate Installation

Transducer cable installation for a hinged gate is shown in Figure 44. This also applies to personnel gates. However, with the personnel type of gate, the conduit can be installed over the top of the gate if space permits. Two weatherproof, electrical junction boxes are mounted on the fence — one on either side of the gate as close as possible to an upright support post. These are interconnected by a 3/4-inch diameter conduit which is buried beneath the ground surface. The conduit depth should be a minimum 18 inches. NOTE: Nonsensitive cable must be used in the conduit connecting the two fence mounted transducer cables. Splice the nonsensitive cable to the transducer cable in each weatherproof junction box. Use a TSK to accomplish the splice [see Transducer Service Kit (TSK) Installation] and fill the TSK with Dow Corning 4 electrical insulating compound before sealing.

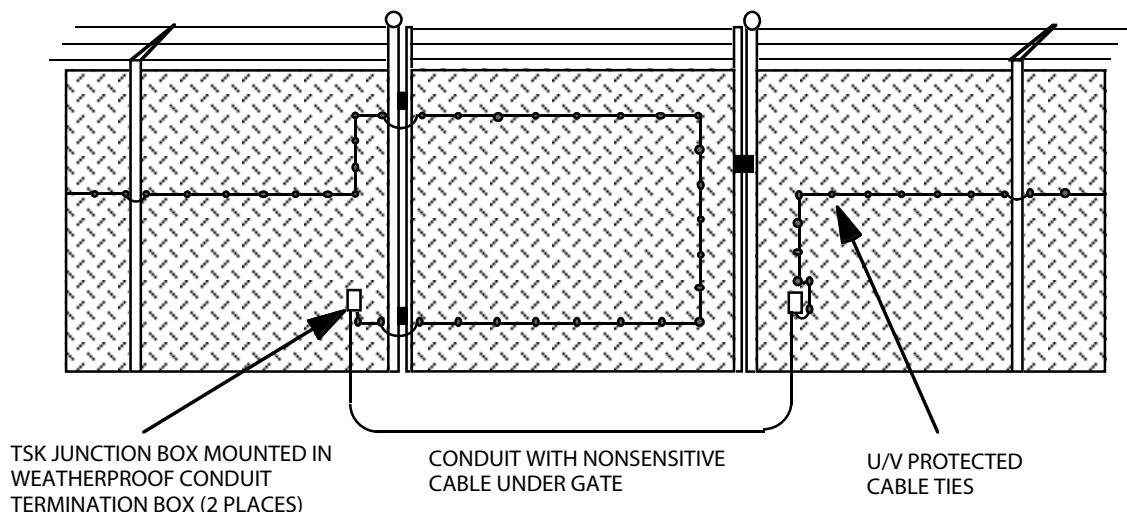

Figure 44. Hinged Gate Installation

As the transducer cable approaches the gate, it is tied to the fence fabric, turned and run up vertically approximately one foot, then turned horizontally and tied to the upright gate support post near, but not on, the upper hinge. Route the transducer cable across the gate support post and gate post using a strain relief, such as Panduit 1/8" T12F-0, or similar, spiral wrap material and fasten to the gate fabric as shown. The spiral wrap will prevent abrasion and excessive movement in the wind. Route the transducer cable in a large loop around the gate and return to the fence near the lower hinge point as shown. Utilize another strain relief to pass back across the hinge area to the fence fabric. Route the transducer cable on the fence to the weatherproof junction box making sure to provide the transducer cable drip loop shown and entering the junction box from the bottom (the drip loop and coming into the bottom will prevent moisture buildup in the junction box). A gland type cable fitting is recommended at the entrance to the junction box. Using a TSK, splice the transducer cable to the nonsensitive cable in the junction box. Route the nonsensitive cable in the conduit to the junction box on the other side of the gate. Splice here again to the transducer cable using a TSK and continue the transducer cable down the fence as shown. If a double swinging gate is encountered, the transducer cable should be routed and attached to the second half of the gate as explained for the first half.

Gate Bypass Unit

A gate bypass unit (GBPU) is sometimes used to temporarily disconnect the transducer cable installed on a swinging gate. If a GBPU installation is required, please refer to the Gate Bypass Unit Installation Instructions furnished with the GBPU.

Telegate Installation

Each Telegate requires installation of a support post. See Figure 45. The support post must be located correctly to ensure proper Telegate operation. The support post and Telegate must be positioned to extend and retract the armored nonsensitive cable as the gate is opened and closed.

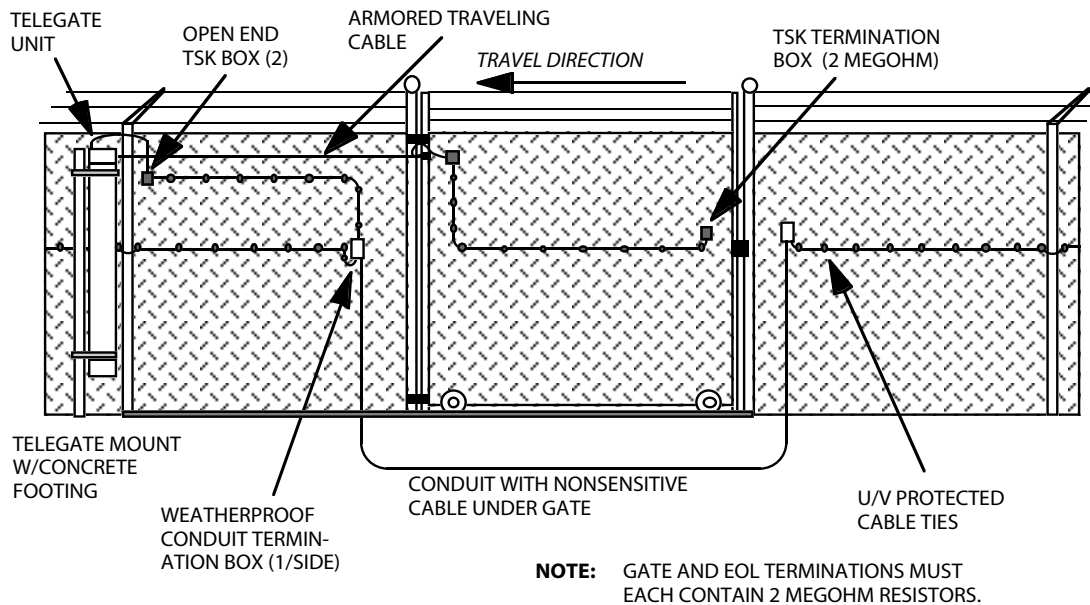

Figure 45. Telegate Installation

The recommended position of the support post for each Telegate is approximately 5 feet from the end of the sliding gate when opened to the maximum position, and not less than 1 foot or more than 2 feet from the centerline of the fence posts on the gate side of the fence. See Figure 46. A 4-inch support post is recommended. The post material should be the same as the fence posts. The support post height must be sufficient that the support post is as tall as the fence and a minimum of 10 feet above ground level. A minimum of one foot space is required between the Telegate bottom and the ground to allow for drainage. The support post footing should be 24 inches deep minimum.

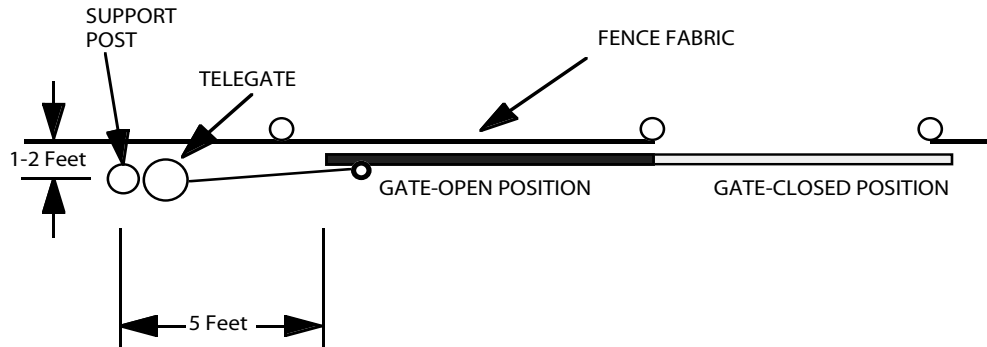

Figure 46. Telegate Support Post Location

Unless the Telegate is exactly at the end of an FPS zone or its own FPS zone, a conduit must be run under the gate opening to continue the zone wiring as shown in Figure 45. This conduit should terminate on each fence section using weatherproof electrical bell boxes and TSKs as shown. It is recommended that the support posts, conduit and gates be installed before the Telegate is unpacked and installed.

Each Telegate is shipped completely assembled and is packed in a wooden crate. The Telegate has a 65-pound weight secured in the middle of the PVC tube enclosure. The weight is held in place for shipping between a cable to the bottom cap and the armored cable and pulleys. Unpacking and preparation for installation involves removing the Telegate from the crate, removing the bottom cap, uncoiling the armored cable and lowering the weight to the bottom of the tube. Uncrate and set up each Telegate as follows:

CAUTION: Once a Telegate is unpacked and the weight and pulley systems are released, the Telegate should remain upright with pull on the armored cable so the cable is not allowed to fall off the pulleys and become tangled. Unpacking the Telegate at the installation location is recommended.

- Step 1 Lay the crate on its side with the top side up. Remove the top of the crate.
- Step 2 Carefully remove the Telegate assembly from the crate.
- Step 3 Remove the cable retaining bolt located in the center of the bottom cap. Removal of this bolt releases the cable that is holding the 65 pound weight in place.

- Step 4 Remove the bottom cap by first removing the three 1/4-inch screws. Remove the cap by gently tapping the lip.
- Step 5 Remove the cable tie and tape and uncoil the armored cable at the top of the Telegate tube. Be careful because when you uncoil the cable the weight can fall to the bottom of the Telegate tube. Hold the armored cable and gently lower the weight to the bottom of the tube.
- Step 6 With the weight at the bottom of the tube, remove the screw and cable attached to the bottom of the weight.
- Step 7 Gently pull on the armored cable to verify that the weight is moving freely in the tube.
- Step 8 Replace the bottom cap using the three 1/4-inch screws. You may wish to store the shipping bolts and cable in the cap in case you ever have to remove and ship the Telegate.
- Step 9 The Telegate is ready for installation.

Attach the Telegate to the support post using the two stainless steel bands provided. See Figure 45. Locate each band approximately as shown. Aim the cable outlet located at the top of the Telegate so the armored cable will pay out straight to the gate. Each band must be tight enough to hold the Telegate in place but not distort the Telegate enclosure.

Open the gate to the maximum opening and attach the Telegate armored cable to the gate using the insulated shackle furnished. The shackle should connect to an eyebolt or other similar device attached to the gate at or near a point that keeps the cable pull horizontal as shown. Leave a minimum 1 foot pigtail for terminating the armored cable to the transducer cable being installed on the gate.

CAUTION: The armored cable is not insulated and must not be allowed to touch any grounded metal parts. If wind conditions force the armored cable to contact the fence, secure a short section of insulating material such as PVC pipe to the fence fabric to prevent contact.

Before making any further connections, operate the gate from full open to full closed making sure that the Telegate armored cable is extended and retracted correctly. Make required mechanical adjustments before Telegate electrical connections.

Two short sections of nonsensitive cable are furnished with each Telegate to make connections. Terminate the nonsensitive cable running from the top of the Telegate to a TSK mounted on the fence as shown in Figure 45. Route nonsensitive cable from the TSK to the bell box as shown. Fill all TSKs with Dow Corning 4 silicone grease, or equivalent, before sealing.

Terminate the armored cable to the transducer cable being installed on the gate using a TSK located approximately as shown. Install the transducer cable on the gate in the same manner as the fence. Terminate the other end of the gate mounted transducer cable with another TSK. To maintain supervision of all transducer cable in the zone, the TSK at the end of the gate mounted transducer cable must contain a 2 Megohm resistor, and the TSK at the end of the FPS zone must also be a 2 Megohm resistor to maintain the net 1 Megohm supervision of each FPS zone.

CAUTION: Use only factory supplied or 1% metal film EOL resistors. Carbon and other resistors are not stable and must not be used.

Microwave Gate Protection

The Magal-Senstar MPS-4100 microwave system provides coverage of the area around a gate while allowing the gate to move freely. See Figure 44. The FPS transducer cable can terminate at the end of a zone on either side of the gate or nonsensitive cable can be spliced and run underground in conduit to continue the zone.

Please see the MPS-4100 Installation and Operation Manual for installation information.

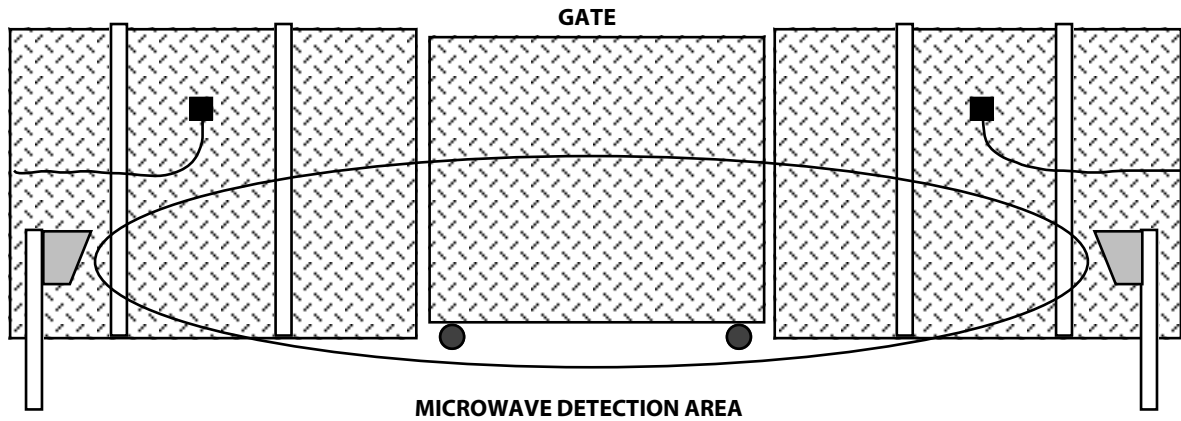

NOTE: FPS is stopped 1-2 panels from gate to eliminate nuisance alarms when gate moves.

Microwave overlap protects the area where FPS does not sense.

Figure 47. MPS Microwave System

Transducer Cable Connections

The pre-amp transducer cable connections are very important to the operation of the sensor system. Before proceeding with transducer cable terminations, the transducer cable should be completely installed and terminated in the zone and the transducer cable extended through the conduit and/or the pre-amp cable glands into the pre-amp enclosure. To connect the transducer cable to the pre-amp, proceed as follows:

- Step 1: Strip outer insulation of the transducer cable 1 inch from the end.
- Step 2: Open the entry gland by rotating the outer shell one full turn counter clockwise.
- Step 3: Pull transducer cable through to the inside of the processor enclosure.
- Step 4: Pull braided shielding back 3/4 inch from outer conductor and twist.
- Step 5: Strip center conductor insulation back 1/4 inch from the end.
- Step 6. Attach the center conductor and the braid to the screw terminal located on the lower edge of the pre-amp board as shown in Figure 48. Be sure to separate shield and center conductor at terminal block to avoid noise in audio. If you are installing a double run sensor cable, attach the other end of the sensor cable to the 1 meg ohm terminations as shown in Figure 48.

- Step 7 Allow enough transducer cable inside the pre-amp enclosure to permit future service.
 Step 8: Close the entry gland by rotating clockwise the outer shell until the cable is held snugly. DO NOT OVER TIGHTEN!

Interconnect Wiring

Each dual zone pre-amp requires a wiring connection to the FPS-3 Central Controller, which provides power and signal connections for the two alarm zones. The wiring consists of a dedicated 2-pair, individually shielded, 24-gauge low capacitance cable with drain wire and high density polyethylene jacket, Magal-Senstar Part No. FPS-3 Interconnect. Use only the approved cable to connect each dual zone pre-amp to the FPS-3 Central Controller. Other cables may not provide adequate performance.

Connect the wiring at each dual zone pre-amp as shown in Figure 48. This connector is removable, making it easier to connect the wiring. Insulate the shield wire so that it does not short or touch the chassis.

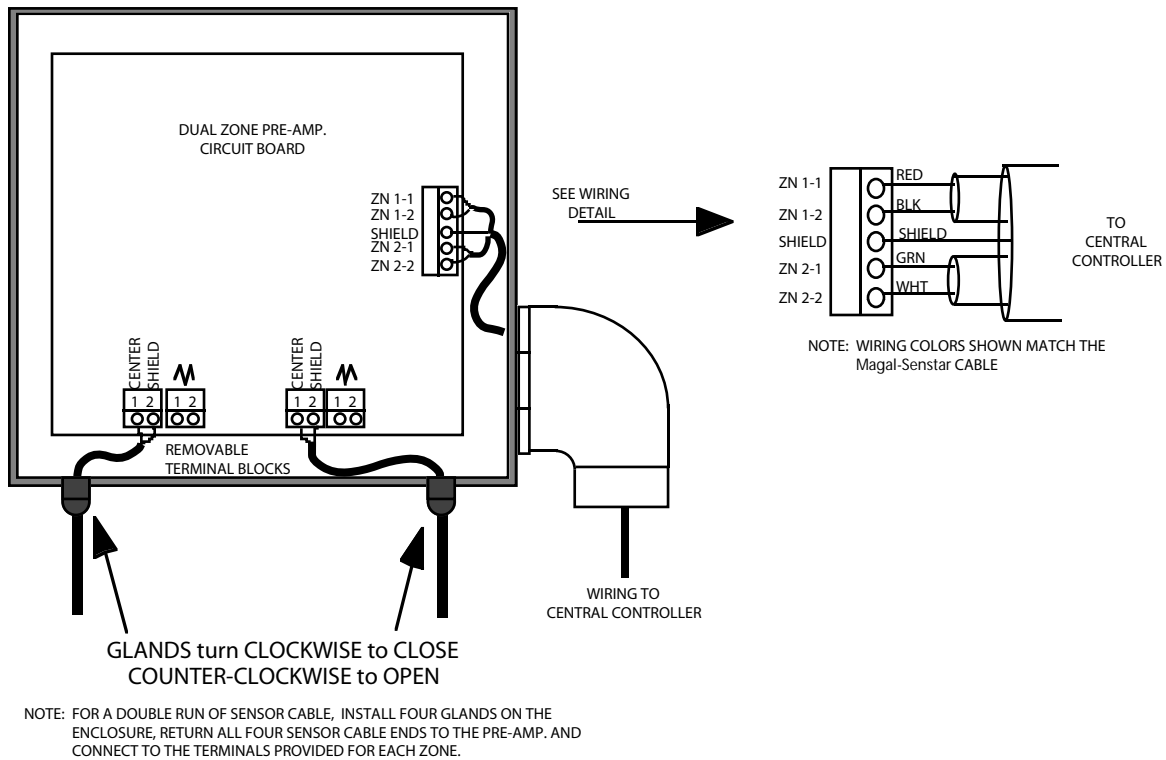

Figure 48. Pre-amp Cable Connections

Connect the wiring from each dual zone pre-amp to the FPS Central Controller as shown in Figure 49. Insulate the shield wire so that it does not short or touch the chassis. Strain relieve the cable, leaving the FPS-3 chassis so that wiring is not damaged when the Central Controller is moved.

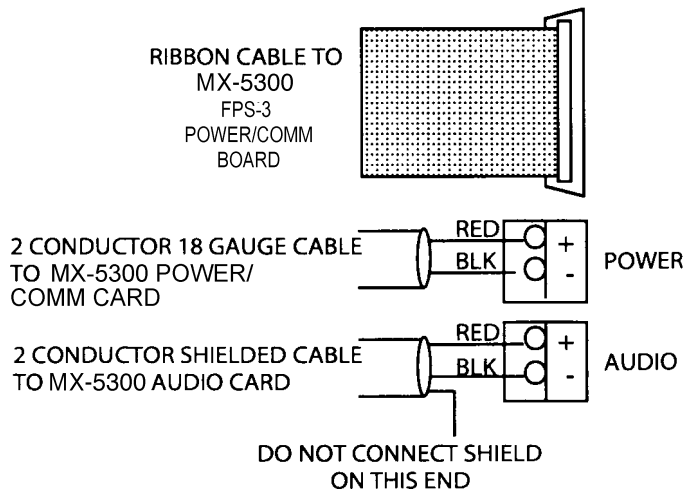
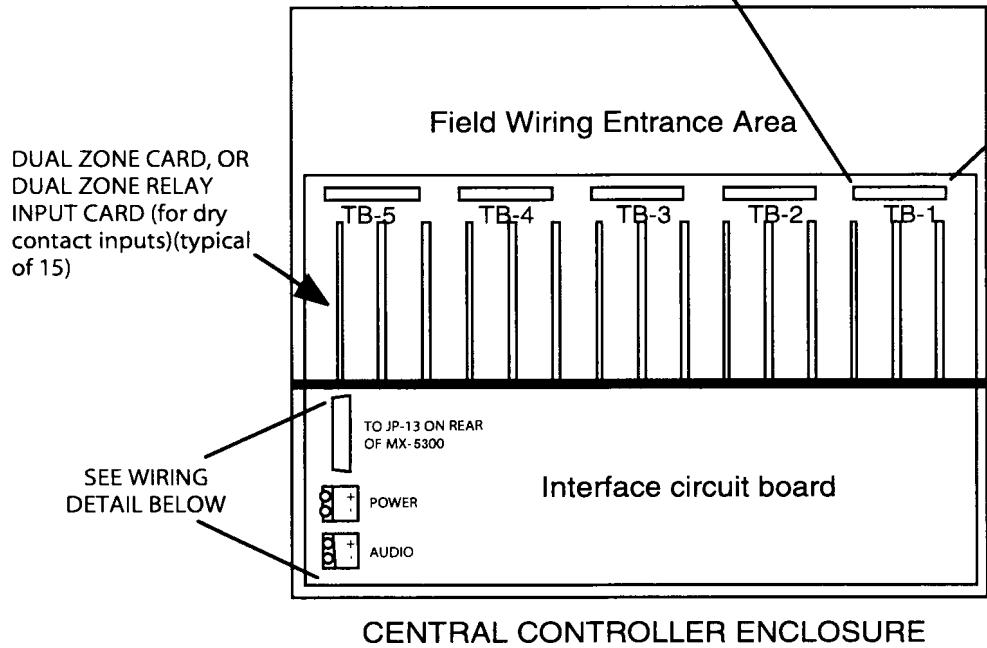
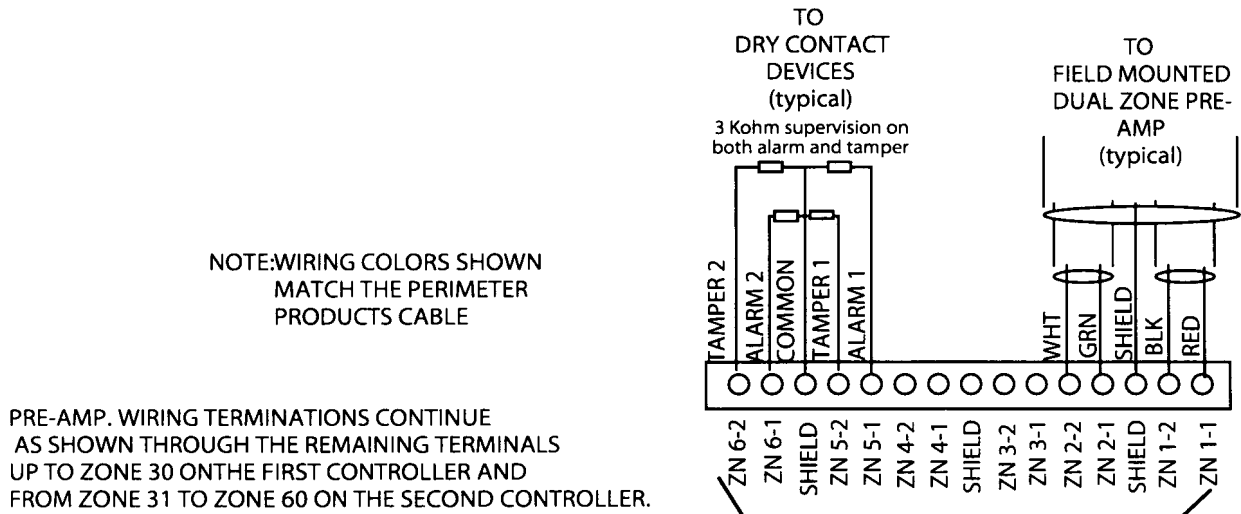

Figure 49. Central Controller Cable Connections

Connect wiring from dry contacts that are being monitored by the FPS-3 as shown in Figure 50. For proper supervision of the remote dry contacts and wiring, inputs should be normally closed with a 3k OHM end-of-line resistor at the device as shown on the figure. For unused inputs, or when connecting unsupervised, normally open devices, place jumper A1 (alarm 1), T1 (tamper 1), A2 (alarm 2), or T2 (tamper 2) in 3k position. Otherwise jumpers should be in NORMAL position.

Connect the wiring from the FPS-3 Central Controller to the MX-5300. See Figure 49.

This wiring consists of:

- A 25-conductor ribbon cable connecting the DB-25 male connector on the FPS-3 Power/Comm card inside the MX-5300 to the DB-25 connector on the FPS-3 Central Controller Interface board.
- A two-conductor, 18-gauge cable connecting the MX-5300 Power/data terminals to the +15 VDC terminals on the FPS-3 Central Controller Interface board. Observe correct polarity.

Verify all wiring connections before proceeding with power up or testing.

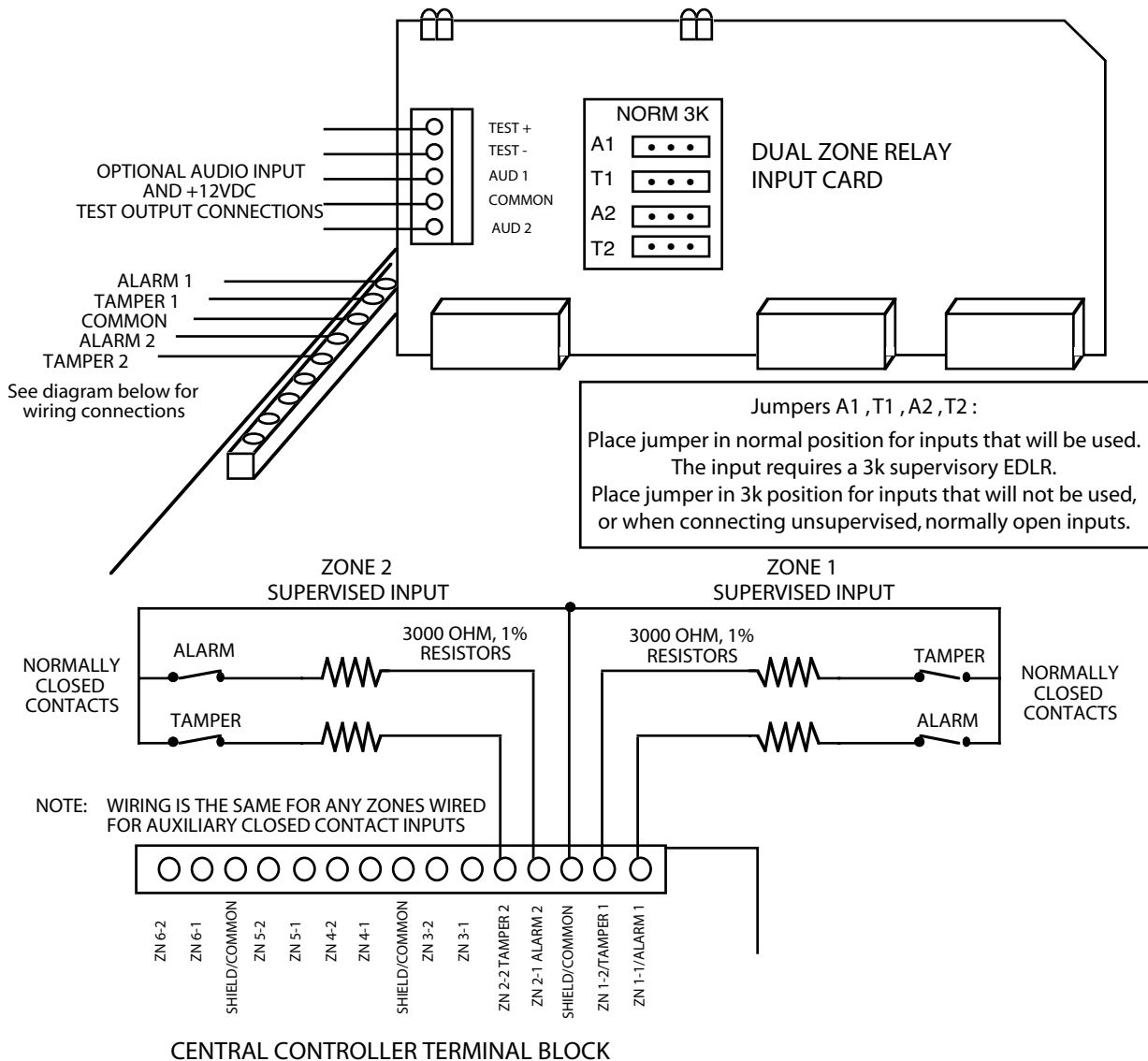

Figure 50. Dual Zone Relay Input Board Wiring Connections

6 SYSTEM STARTUP AND TESTING

General

System startup and testing consist of powering up the system and making tests to verify proper operation and detection of fence disturbances. The Magal-Senstar Field Performance Analyzer (FPA) and a good quality ohmmeter capable of reading 1 megohm \pm 10% and resistances of up to 10 megohms are required.

Once all system components are installed and interconnected, power will be applied and the system adjusted and tested for proper operation. This procedure involves the following steps:

- ▷ Verify wiring connections.
- ▷ Apply power to the FPS-3 Central Controller and MX-5300.
- ▷ Perform tests at the FPS-3 Central Controller.
- ▷ Perform tests and record measurements at each field-mounted dual zone pre-amp.
- ▷ Adjust FPS-3 Central Controller/MX-5300 based on field measurements.

Verify Connections

Before proceeding with system startup, verify that:

- ▷ All equipment has been installed and connected.
- ▷ The FPS-3 Central Controller is correctly connected to the MX-5300. Connections are local bus ribbon cable, audio cable and power connections. See Figures 9 and 49.
- ▷ FPS-3 Central Controller internal switch settings should be:
 - Address switch SW1 set for correct controller address. Default factory setting is for zones 1-30. See Figure 51.
 - Jumper JP2 installed for zones 1-30, removed for zones 31-60. See Figure 51.
 - The gain setting for all zones set to 4. This is the normal factory default setting. See Figure 52.

Applying power

Apply power to the MX-5300. This will power both the MX-5300 and the FPS-3 Central Controller.

If this system has not been previously powered and programmed, the MX-5300 display may show communications failures or other alarm indications. Properly program the MX-5300 before proceeding with systems tests.

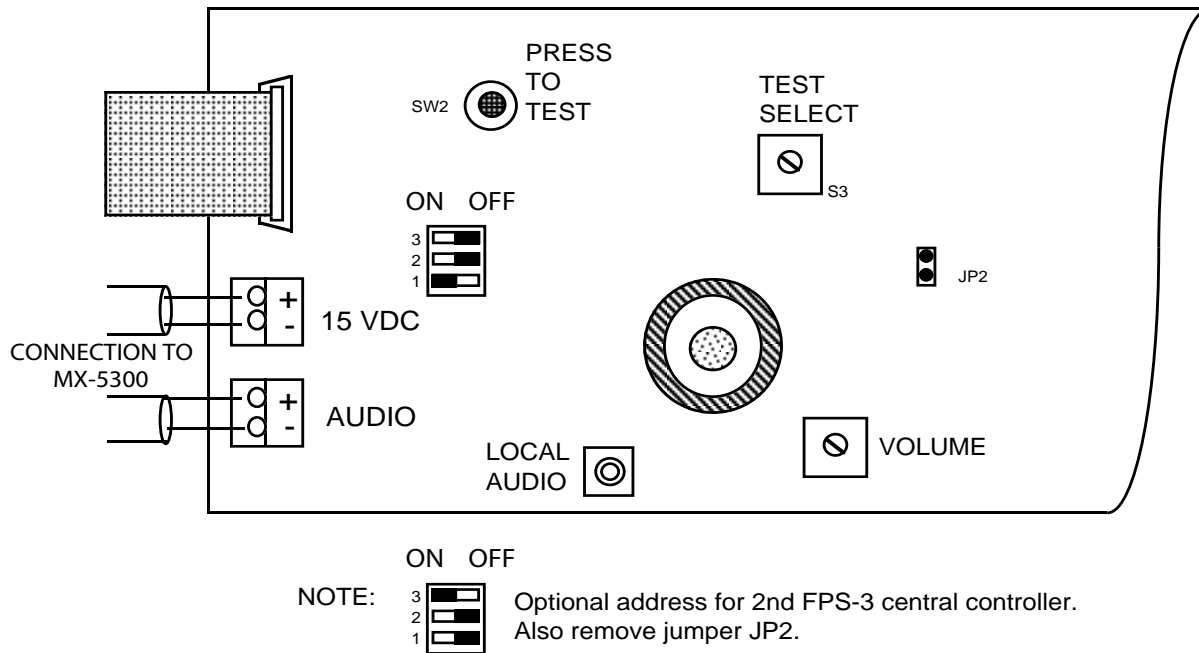

Figure 51. Interface Board Connections and Controls

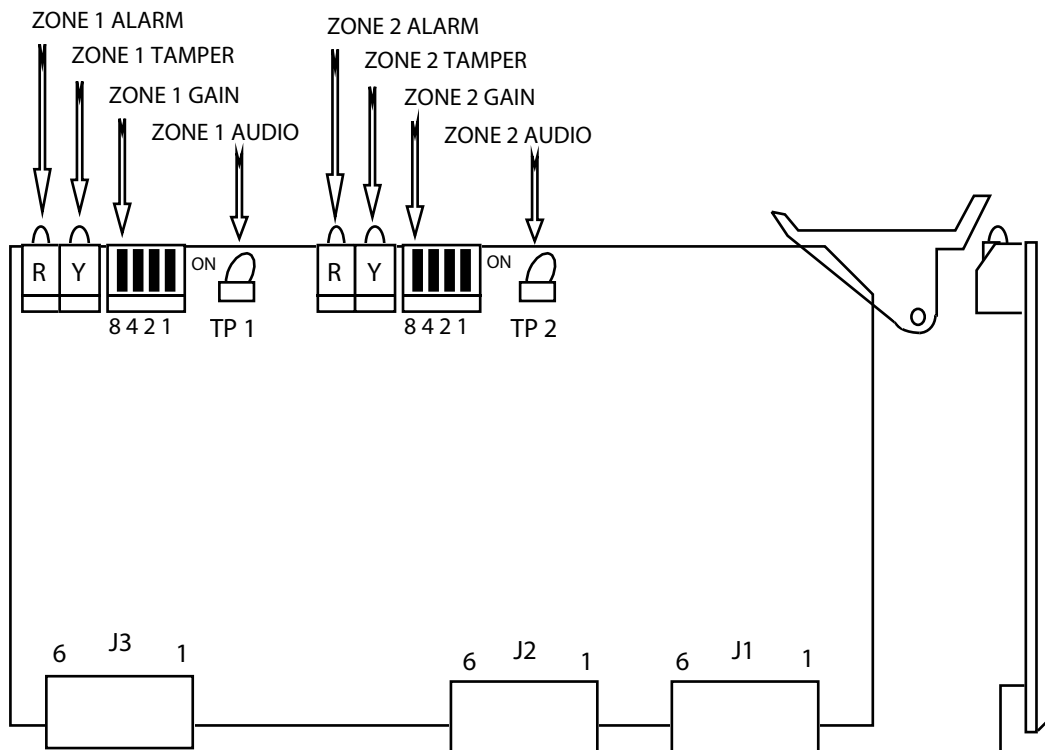

Figure 52. Dual Zone Card

Programming the MX-5300

The MX-5300 contains flexible programming features allowing the connection of up to 30 FPS-3 alarm zones and up to 30 conventional alarm zones (i.e., FPS-2-2, G-Line, and stand-alone transponder), for a maximum of 60 alarm zones total.

Alarm zones are assigned in the MX-5300 as follows:

Conventional alarm zones

Up to 20 conventional alarm zones (1 through 10 conventional processors containing 2 zones each) may be assigned to communications loop 1. Up to 10 conventional alarm zones (11 through 15 conventional processors containing 2 zones each) may be assigned to communications loop 2. These zones should be programmed as conventional zones as described in the MX-5300 manual.

FPS-3 alarm zones

FPS-3 alarm zones may be assigned on any loop. Any zones on loops 1 and 2 beyond the number of conventional zones may be selected as FPS-3 alarm zones up to 20 zones per loop. For example, if loop 1 has 14 conventional zones, 6 FPS-3 zones may be assigned for a total of 20 zones. The same applies for loop 2, except that loop 2 is limited to 10 conventional zones reporting from up to 5 processors. Loop 3 may be assigned FPS-3 alarm zones only.

For programming purposes, addresses 16.1 to 30.2 are reserved for FPS-3 zones only and are assigned as follows:

- ▷ The first dual zone card on the FPS-3 backplate is assigned addresses 101.1 and 101.2. Any inputs, whether FPS-3 or auxiliary dry contacts, wired into this slot are addressed 101.1 and 101.2. (MX-3000)
- ▷ The second slot is assigned addresses 17.1 and 17.2, and so forth, through the fifteenth dual zone card slot which is addressed 30.1 and 30.2.

For detailed MX-5300 programming information, please refer to the MX-5300 manual.

The following is a summary of the steps required to program for the FPS-3 connected zones.

1. Perform Code 8 programming to set the modem locations. Set the number of zones for each loop. Note that any conventional alarm zones must be included in the Code 8 programming.
2. Perform Code 0 programming to assign alarm zone numbering (the zone numbers that appear on the MX-5300 displays). Code 0 allows you to assign a zone number to each of the alarm zone addresses. The FPS-3 addresses begin at the first address of 16.1 and continue to the 30th address of 30.2. When using two FPS-3 Central Controller units, the addresses for the second unit begin at 31.1 and continue to 45.2. After accessing the MX-5300 programming mode, press 0 and the ACK key for the Code 0 mode. The LCD screen will read Zone 01:01.1. Use the keypad to enter the correct address for zone 1 and press the ACK key. Continue through all zone assignments for your system. Note that the zone assignments for any conventional zones must be programmed at the same time. It is possible to skip zones during code 0 programming. To skip a zone number, when the zone number appears on the display, press the AUD ON key to toggle the display to read "DISABLE." Press the ACK key to move to the next zone. When the last zone has been programmed, press the "0" digit, or use the AUD ON key to toggle the display to read "DONE EDITING." Press the ACK key to leave the Code 0 programming mode.
3. Perform Code 14 programming to set FPS-3 zones and conventional zones for EDAPT operation. All FPS-3 zones, except those connected to auxiliary input cards should be programmed for

EDAPT operation. Also, selected FPS-2-2 zones may be programmed for EDAPT operation. After accessing the MX-5300 programming mode, press 14 and the ACK key for the Code 14 mode. The LCD screen will read XPO1:STD. Note that the XPO numbers are the conventional processor numbers beginning at XPO1 and that each XPO encompasses 2 alarm zones. Note also that the first FPS-3 address is addressed as XPO101 (conventional processor 16). Utilize the AUD ON key to toggle through the programming choices for each XPO address:

STD All XPOs not programmed for EDAPT or FPS-3 Auxiliary Input Cards.

EDAPT All FPS-3 XPOs and selected FPS-2-2 XPOs for EDAPT operation.

CONTACT All XPOs where the FPS-3 Auxiliary Input Cards are installed. When you have selected the correct choice for each XPO, press the ACK key to move to the next XPO.

4. Perform Code 12 programming to select the counts for each EDAPT programmed zone. Previously under programming Code 14, EDAPT XPOs were programmed. Each XPO encompasses two alarm zones. The count is the number of alarm "hits" that the system must receive to produce an alarm. The count can be set from 1 to 10. The factory default setting is 4. After accessing the MX-5300 programming mode, press 12 and the ACK key for the Code 12 mode. The LCD screen will read ZONE "x" LVL 4. The "x" is the number of the first zone that was programmed for EDAPT operation under Code 14 above. Use the keypad to enter the count number for this zone based on the information contained in Table 2, page 59. Press the ACK key to go to the next zone. Continue through all zones.

Note: If you have not yet made the field measurements and filled out Table 2, you should leave the Code 12 programming at the default setting and return to program Code 12 following the field testing.

Following completion of programming, all MX-5300 front panel lamps should be green. All FPS-3 Central Controller zone receiver board alarm (red) and tamper (yellow) lamps should be off. If these conditions are not present, refer to the troubleshooting section.

FPS-3 Central Controller Tests

Perform tests at the central controller as follows:

- ▷ Plug the audio test lead into the Local Audio connector located on the controller interface circuit board. See Figure 51. (This allows you to listen to the audio from each dual zone pre-amp. during testing.)
- ▷ Connect the audio test lead alligator clip to the Zone 1 audio test point, TP1. See Figure 52.
- ▷ Using a small screwdriver set the Test Select switch, S3, to the first dual zone card number. The test select switch is shipped in the 0 or off position. Please note that the test select switch is marked with hexadecimal marking so the first dual zone card is one, the tenth dual zone card is marked "A," continuing to the fifteenth card which is marked "F."
- ▷ Press and release the Push to Test switch, SW2. Upon pressing the test switch you will hear up to 15 test pulses through the test loudspeaker. These test pulses are being generated at the dual zone pre-amp representing that pair of zones. The two tamper alarm lamps should light immediately after pressing the test button. The two red alarm lamps will light after about the fourth test pulse. The red alarm lamps and the yellow tamper alarm lamps will extinguish after about five seconds. Note if the operation is correct and proceed to the next zone. Refer incorrect operating zones to the troubleshooting section.
- ▷ Any zones showing incorrect operation should be repaired before proceeding with further tests.

Dual Zone Pre-Amp Tests

Following the FPS-3 Central Controller tests proceed to the field to test each dual zone pre-amp as follows:

- ▷ Visually inspect the entire length of the transducer cable to verify proper installation, free from abrasions or breaks in the outside jacket. Pay particular attention to the following:
 - Where the cable crosses each post.
 - Service loops every 40-50 feet (every 100 feet with Helisensor).
 - Special conditions at corner posts and ends of zones.
 - The installation of each TSK.
 - Dow 4 Compound in each TSK.
 - Drip loops provided at each TSK, EOL, conduit and dual zone pre-amp.

NOTE: These tests must be conducted using the FPS-3 Field Performance Analyzer (FPA). There are no adjustments or settings at the dual zone pre-amp.

- ▷ Open the front door of the dual zone pre-amp. Note that this will set off a tamper alarm at central control.
- ▷ Remove the five-position output terminal strip, TB3, by unplugging it from the circuit board. Plug-in the identical five-pin terminal strip from the FPA. The FPA provides a local alarm panel and allows you to test and adjust these two zones. Operate the FPA in accordance with the FPA instruction manual.
- ▷ Unplug each sensor cable and test with an ohmmeter for leakage between conductors and leakage to ground.
 - With the end-of-line termination installed, the center conductor to shield resistance should be 1 megohm \pm 10 %.
 - The resistance from shield to ground (i.e., fence, conduit, helisensor covering, etc.) should be 10 megohms minimum.

If either of these measurements are not within the specified limits refer to the Troubleshooting section.

- ▷ Determine the sensitivity and count adjustments by performing tests on fence panels in each zone. Use the form located at the end of this section, Table 2, to record the gain and count settings for each alarm zone. This information will be used later to make final adjustments at the FPS-3 Central Controller and the MX-5300.
- ▷ Determining the best sensitivity and count settings.
 - Begin testing with an initial sensitivity (gain) setting of 4 and an initial count setting of 4. These settings should provide excellent fence protection operation in most installations.
 - Sensitivity should be determined by tapping on the fence fabric with a metal object, such as a screwdriver, and by actual climb tests.
 - Generally speaking, increasing the gain in the zone increases the possibility of nuisance alarms. As the gain is increased, the fence is more susceptible to producing alarm counts from movement, wind, etc. Increasing the count in the zone decreases the possibility of nuisance alarms by requiring more qualifying hits (hits that exceed the gain threshold) to produce an alarm.

- When making adjustments, the gain switch is used as the coarse adjustment, while the count switch is used for the fine adjustment.
- ▷ Following completion of tests at the pre-amp, disconnect the FPA, reconnect the output wiring, close and fasten the front door, and proceed to the next pre-amp location.
- ▷ Once the testing at all pre-amps. is complete, proceed back to the Central Controller/MX-5300 to enter the field measured values.

Adjust FPS-3 Central Controller/MX-5300

Utilize the gain settings recorded on Table 2 to adjust the gain switches at the FPS-3 Central Controller as follows:

- ▷ Locate the gain switches on the dual zone card. See Figure 52.
- ▷ Enter the gain settings from Table 2 for each zone in the system. Note that the typical gain setting is 4. Your gain settings may vary slightly from zone to zone. Note that the gain setting is accomplished with four switches, with binary values of 1, 2, 4 and 8. Gain can be set from 1 to 10 using combinations of these switches.
- ▷ When all gain settings are complete, proceed to the MX-5300 to set the counts for each zone following the instructions provided in the Programming the MX-5300 section, page 55. For additional information, please refer to the MX-5300 manual.

Upon completion of these tests and adjustments your system should be ready for final testing.

System Checkout

By the time you are ready for system checkout and final testing, the transducer cable, pre-amps, and Central Control equipment should be installed and operating properly and the operational tests should be complete. System checkout usually involves testing the complete system from the fence to the central control point including alarm control and remote alarm annunciation.

The system test is performed by having a person climb each fence panel and verifying that the climb has been detected. This should be done using someone weighing in the range of 100-130 pounds. Have the test subject climb the fence at various locations within the system, and within each fence panel if possible.

IMPORTANT: BE CAREFUL NOT TO DAMAGE THE SENSOR CABLE WHILE PERFORMING CLIMB TESTS.

Be sure to perform the climb test for each zone. It is not uncommon to have different gain and count settings on different signal processors within a multiple zone system. Remember, the switch settings are designed to allow the sensor to be customized for fence conditions, height, and customer requirement.

7 MAINTENANCE / TROUBLESHOOTING

General

The entire system will continue to perform efficiently only if it is properly maintained. It is highly recommended that the entire system be thoroughly tested and tuned once every three to four months.

The Fence

This is the portion of the system that will require the largest share of maintenance. **THIS IS IMPORTANT!** Fence conditions can deteriorate rapidly due to:

- ▷ Severe winters
- ▷ Strong winds
- ▷ Growing shrubbery and trees
- ▷ Employees stacking material against fence or running into it with vehicles
- ▷ Old signs working loose or facilities personnel installing new signs
- ▷ General weakening of fabric-to-support tie-down connectors

During each maintenance check, be sure to test all fencing as outlined in Section 4, making sure that it is still quiet! If necessary, quiet the fence as described in Section 4.

The Transducer Cable

The transducer sensor cable is designed to withstand years of weather and environmental conditions. It is important, however, that you give attention to the following areas:

Visually inspect all cable runs making sure:

- ▷ Cable is taut (but not bowstring tight).
- ▷ All cable ties are intact.
- ▷ End of line resistor and any splices are properly sealed.

Perform cable continuity tests as outlined in Section 6.

Transducer Cable Repair

If the transducer cable is damaged by an abrasion or cut, one or both of the following conditions may exist.

- ▷ The outer shield will short directly against the fence fabric.
- ▷ Moisture will cause a partial short between the center conductor and the outer shield, thereby shorting the end-of-line supervision resistor (1 Megohm) to below the tolerance level of 900 K ohms. This in turn will cause the signal processor tamper alarm to go into an ALARM STATE until the damaged area is repaired.

NOTE: Tamper alarms caused by moisture penetration can be intermittent.

To repair a damaged transducer cable, splice kits are available from MSI that require no special tools and can be performed in about 5 minutes. (See Section 5, TSK Installation)

Systematic Testing

Problems sometimes occur due to equipment failures. However, in most cases, problems are caused by human or installation related items such as:

- ▷ Shipping damage
- ▷ Disturbed wiring or connections
- ▷ Incorrect connections
- ▷ Physical damage
- ▷ Defects in the fence installation

Always look for the simplest problem first. For example, always check for power supply voltages before starting any further testing.

When approaching a system malfunction, look first for a related activity that could have caused the problem. This will help you go directly to the possible problem areas and/or obtain more accurate factory assistance. Examples are:

- ▷ Recent maintenance actions or installations of other equipment in the same area or equipment rooms.
- ▷ Water or lightning damage.

Factory customer assistance is available to help you find and correct system errors. It is important that you keep your as-built documentation and test records so the factory will have the data needed to help resolve your problem.

Problem Identification and Resolution

The FPS-3 has designed-in troubleshooting tools to help you determine the cause of a problem and make rapid repairs.

NOTE: Portions of this procedure require the use of the Field Performance Analyzer (FPA), the FPS-3 companion test set.

Problems can be generally divided into two categories:

- ▷ Problems that affect all zones or a group of zones. These problems can usually be traced to the FPS-3 central controller or the MX-5300.
- ▷ Problems that affect individual zones or two adjacent zones (i.e., two zones from one field-mounted pre-amp. These problems can usually be traced to one field mounted pre-amp, the sensor cable for that zone, or the cable running from the central controller to the pre-amp.

All troubleshooting should begin at the FPS-3 Central Controller. Follow this procedure to begin troubleshooting:

NOTE: Do not go to the fence mounted equipment before first checking the central controller.

- ▷ If you have a problem that is affecting all system zones or at least one group of adjacent zones, proceed to Table 4 to isolate the problem to a component of the FPS-3 interface board.
 - Table 4 allows you to troubleshoot to the FPS-3 interface board integrated circuit component level.
 - The FPS-3 interface board components are installed in plug-in sockets to facilitate easy field replacement.
- ▷ Open the FPS-3 central controller to gain access to the test functions.
- ▷ Observe the red alarm lamps and the yellow tamper lamps on each FPS-3 zone receiver board.
 - A red alarm lamp indicates that an alarm is present at the fence. This problem can probably be traced to the field mounted preamp or the fence-mounted sensor cable.
 - A yellow tamper lamp indicates that a tamper is present at the field-mounted preamp. This problem can probably be traced to a problem with the fence mounted sensor cable or terminations.
- ▷ Test the suspect zone(s) as follows:
 - Plug the audio test lead into the Local Audio connector located on the controller interface circuit board.
 - Connect the audio test lead alligator clip to the suspect zone audio test point, TP1. See Figure 52.
 - Using a small screwdriver set the Test Select switch, S3, to the Dual Zone Card being tested. Note that the test select switch is marked with hexadecimal marking so the first zone is one, the tenth zone is marked "A" continuing to the fifteenth zone which is marked "F."

- Press the Push to Test switch, SW2. Upon pressing the test switch you should hear up to 15 test pulses through the test loudspeaker. These test pulses are being generated at the dual zone pre-amp representing that pair of zones. The two tamper alarm lamps should light immediately after pressing the test button. The two red alarm lamps will light after about the fourth test pulse. The red alarm lamps and the yellow tamper alarm lamps will extinguish after about 5 seconds. If operation is not correct, proceed to the Troubleshooting Table 3.
- ▷ If you suspect that the trouble is caused by the Dual Zone Card swap it with a known good Dual Zone Card, either a spare or by exchanging the suspect board with a known good board from another slot.
 - If the problem stays at this slot, the problem is probably at the field-mounted dual pre-amp.
 - If this problem disappears the problem is probably in the Dual Zone Card. Return a defective card to the factory for repair.
- ▷ Proceed to the fence mounted Dual Zone Pre-Amp to troubleshoot problems that appear to be coming from the field.
 - Utilize the FPS-3 Field Performance Analyzer (FPA). Operate the FPA in accordance with the FPA instructions.
 - When tamper alarms are present, begin by testing the sensor cable continuity; center conductor to shield, and shield to fence. Visually inspect all TSKs for damage.
- ▷ Refer to Table 3 for further troubleshooting information.

Repair

Perform system repairs using good commercial practice. It is recommended that repairs be performed by personnel who have received factory training. Improper repairs or system damage caused by untrained personnel can affect the warranty.

Isolate defective components by swapping field connections with known good components or by using spare components reserved for maintenance actions. Repairs to equipment and circuits contained in the alarm processor are not recommended.

Return components thought to be defective to Magal-Senstar for repair in accordance with the repair procedure. Include information describing the nature of the problem with the returned component. This will shorten factory repair time.

Table 3. FPS-3 Troubleshooting Table		
Symptom	Possible Cause	Recommended Solution
No communications or alarms	No power to MX-5300/FPS-3 controller	Check power connection and battery
	MX-5300 to FPS-3 wiring defective	Check wiring
	MX-5300 programming incorrect	Check programming
ComFail on some or all zones	FPS-3 controller board problem	Refer to Table 4 for troubleshooting
	MX-5300 to FPS-3 wiring defective	Check wiring
	MX-5300 programming incorrect	Check programming
No alarms or tampers from zone	FPS-3 controller board problem	Refer to Table 4 for troubleshooting
	Defective dual zone receiver card	Perform tests at FPS-3 controller
	Defective dual pre-amp	Perform tests at FPS-3 controller Field test with FPA
No audio from zone	Defective dual zone card	Perform tests at FPS-3 controller
	Defective FPS-3 interface board	See Table 4
	Defective dual pre-amp	Field test with FPA
Zone reporting nuisance alarms	Fence is loose and causing problems	Use FPA to check zone Walk zone and look for problem Repair if necessary
	Something hitting fence and causing alarms	Walk zone and look for problem
	Transducer cable to TSK is loose and moving in wind	Walk zone and look for problem
	Transducer cable shield shorted to fence	Use FPA to check zone Check for cable/fence shorting
	Transducer shield or center conductor shorted together or to fence	Use FPA to check zone Check for cable/fence shorting Walk fence to check transducer condition
	Defective end-of-line or TSK installation	Test sensor cable center conductor to shield resistance
Zone is reporting tamper alarms	TSK containing moisture	Examine TSK installations Dow Corning 4 in each TSK

Table 3. FPS-3 Troubleshooting Table (continued)

Symptom	Possible Cause	Recommended Solution
Intermittent tamper alarms reported	See tamper alarms reported above	Test and repair
	Damaged transducer cable shorting when moved by wind, etc.	Carefully examine transducer cable
No alarm or tamper lamps during self-test	Defective dual zone card	Perform tests at FPS-3 controller Swap with known good card
	Defective dual pre-amp	Field test with FPA
	Field wiring shorted	Perform continuity tests
Audio signal low, hum, or garbled	Defective FPS-3 interface board	See Table 4
	Defective dual zone card	Swap with known good card

Table 4. FPS-3 Interface Board Fault Isolation Matrix

SYMPTOM	ZONES AFFECTED	CAUSE	REMEDY	TYPE
NO SYSTEM OPERATION NO SELF-TEST and NO AUDIO COMMUNICATION FAILURE	ALL ZONES	U1	REPLACE	MC78MO5CT
	ALL ZONES	U2	REPLACE	74HCT02
	ALL ZONES	U3, 4, 33, 40 or 41	REPLACE ALL	U3, U41-74HC541 U4-74LS85 U33-74HCT74 U40-74HC1 09
NO SELF-TEST, AUDIO, LEDS, ALARMS OR TAMPERS NO PROCESSOR LEDES	ALL ZONES	U5	REPLACE	74HCT138
	ALL ZONES	U6	REPLACE	74HCT02
	1 through 8	U7	REPLACE	74HC273
	9 through 16	U8	REPLACE	74HC273
	17 through 24	U9	REPLACE	74HC273
NO OPERATOR SELF-TEST	25 through 30	U10	REPLACE	74HC273
	ALL ZONES	U2	REPLACE	74HCT02
	1 through 16	U12 or 42	REPLACE ALL	74HC273
NO ALARM, TAMPER or LOCAL SELF TEST CONSTANT or NO TAMPER	17 through 30	U13 or 43	REPLACE ALL	74HC273
	ALL ZONES	U14	REPLACE	74HC32
	ALL ZONES	U15, 16 or 17	REPLACE ALL	U15-74HC541 U16-74HC1 61 U17-74HC1 39
CONSTANT or NO ALARM	1 through 8	U18	REPLACE	74HC540
	9 through 16	U19	REPLACE	74HC540
	17 through 24	U20	REPLACE	74HC540
	25 through 30	U21	REPLACE	74HC540
	ALL ZONES	U22, 23 or 24	REPLACE ALL	U22-74HC541 U23-74HC161 U24-74HC138
	1 through 4	U25	REPLACE	74HC540
	5 through 8	U26	REPLACE	74HC540
	9 through 12	U27	REPLACE	74HC540
	13 through 16	U28	REPLACE	74HC540
	17 through 20	U29	REPLACE	74HC540
21 through 24	U30	REPLACE	74HC540	
NO AUDIO	25 through 28	U31	REPLACE	74HC540
	29, 30	U32	REPLACE	74HC540
	ALL ZONES	U11	REPLACE	74HC273
	1 through 8	U35	REPLACE	4051
	9 through 16	U36	REPLACE	4051
	17 through 24	U37	REPLACE	4051
	25 through 30	U38	REPLACE	4051
NO AUDIO or ALERT TONE	ALL ZONES	U39	REPLACE	MC34119

ADDENDUM

Field Performance Analyzer

The Field Performance Analyzer, or FPA, is the FPS-3 companion test unit which allows you to rapidly troubleshoot and adjust the FPS-3 system. See Figure A-1.

The FPA is provided with an AC transformer, internal batteries, and cables for performing field tests on FPS-3 dual zone pre-amps. The FPA has a storage compartment for the FPS-3 pre-amp interconnect cable.

The following is a brief description of the FPA operation.

FPS-3 Two Zone Tester Operation

Alarm (No Auto ACK/Reset)

- ▷ Red alarm LED flashes, beeper oscillates, green LED extinguished, and respective alarm relay activates.
- ▷ Operator pushes ACK/RESET button for respective zone.
- ▷ Red LED goes on steady, beeper is quieted.
- ▷ Operator pushes ACK/RESET again to turn red LED and relay off and re-light green LED.

Alarm (Auto ACK/Reset)

- ▷ Red alarm LED flashes, beeper oscillates, green LED extinguished, and respective alarm relay activates all for approx. 3 seconds.
- ▷ At end of alert period, zone is reset; relay deactivated, and if zone is secure red LED goes off, and green LED goes on.
- ▷ If at end of alert period zone is still in alarm, red LED goes to steady on and green LED remains off. When alarm condition is gone the red LED goes off and green comes on automatically.

Tamper (No Auto ACK/Reset)

- ▷ Red tamper LED flashes, beeper oscillates, green LED extinguished, and tamper relay activates.
- ▷ Operator pushes ACK/RESET button for respective zone.
- ▷ Red LED goes steady, beeper is quieted.
- ▷ Operator pushes ACK/RESET again to turn red LED and relay off and re-light green LED.

Tamper (Auto ACK/Reset) – same as alarm (auto ack/reset) condition except tamper LED and relay are activated.

FPS-3 Tester Switch Functions

ACK/RST - Acknowledges and resets alarms and tampers.

Off/On – This switch turns off power to DC-DC converter.

Auto ACK – Auto ack/reset function acknowledges and resets alarms and tampers automatically after about **3** seconds. (Reset occurs provided the condition has cleared.)

Audio 1 – Switches audio from zone 1 on. Zone 1 green LED flashes.

Audio 2 – Switches audio from zone 2 on. Zone 2 green LED flashes.

Test Zones – Initiates self-test of both zones.

Gain – Four position binary code dipswitch controls the signal sensitivity level. Sensitivity is set from 1 to 10 with 1 being the lowest setting and 10 being the highest.

Count – Four position binary code dipswitch that sets the number of impulses required to produce an alarm. Count is set from 1 to 10.

Volume – Controls the volume level of the alert tone and audio output signal.

FPS-3 Tester Zone Testing

- ▷ Operator pushes and releases TEST button.
- ▷ Test button interrupts power to FPS-3 Pre-Amp initiating self test on re-activation.
- ▷ Tester/Annunciator indicates alarm accordingly.
- ▷ Operator can listen to test pulses by activating the audio output of either zone or both.

FPS-3 Tester Audio Functions

- ▷ Alert tone volume is adjustable via pot located on the circuit board inside the chassis.
- ▷ Combined audio (alert tone and zone audio) volume is adjustable via panel mounted volume control.

FPS-3 Tester Power

- ▷ External power is provided by a plug-in 16.5 VAC, 20VA transformer.
- ▷ Internal power is provided by a 12V, 1AH gel cell.
- ▷ Operating power is provided by a DC-DC converter producing 14 VDC from either 12V battery (external power disconnected) or 16.5 VAC, 20VA transformer. Current load is 100mA.

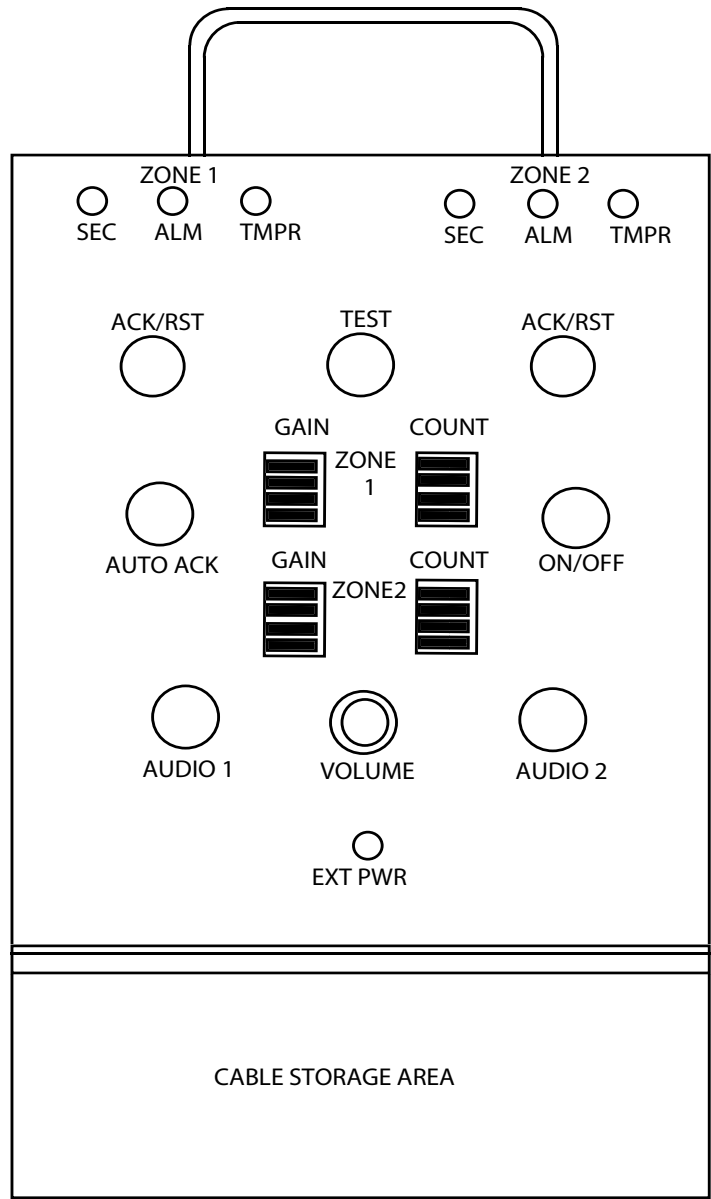
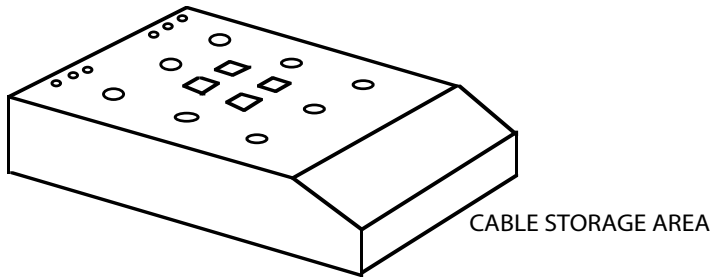

Figure A-1 Field Performance Analyzer